

Instruction Manual

M150 Gas Reactor Column



Declaration of Conformity

We, BOC Edwards ,
Manor Royal,
Crawley,
West Sussex RH10 2LW, UK

declare under our sole responsibility that the product(s)

M150 Gas Reactor Column configured using the M150 matrix modular build structure,
as shown below

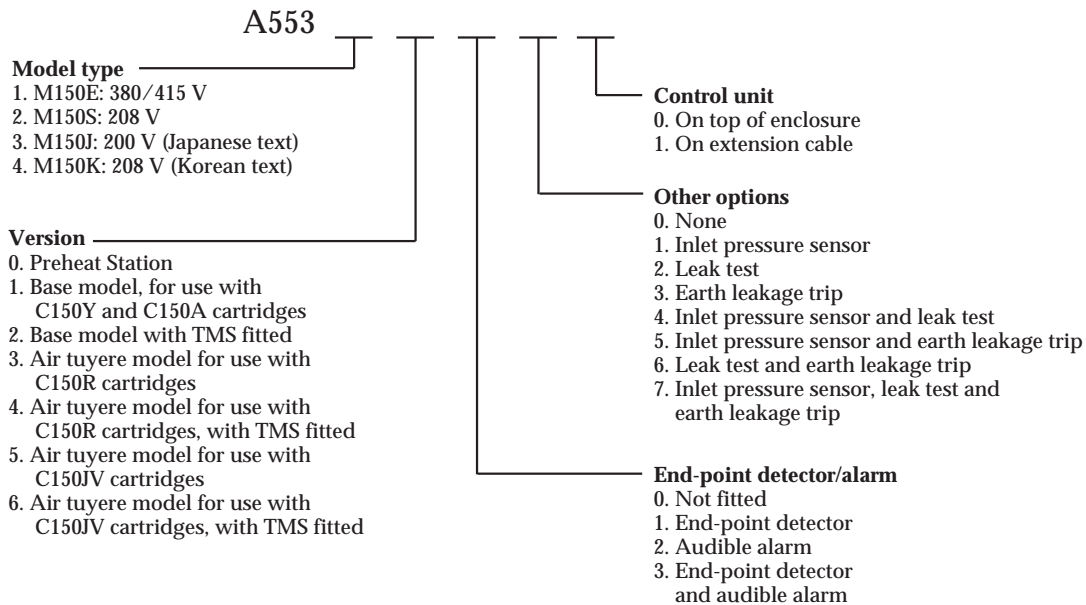

to which this declaration relates is in conformity with the following standard(s)
or other normative document(s)

EN 50081-2	Electromagnetic Compatibility, General Emission Standard. Generic Standard Class: Heavy Industry.
EN 50082-2	Electromagnetic Compatibility, General Immunity Standard. Generic Standard Class: Heavy Industry.
EN 60204-1	Electrical Safety: Machines.
NFPA-79	National Electrical Code - Electrical Safety: Machines.
SEMI S2-93	Safety Guidelines for Semiconductor Manufacturing Equipment.

following the provisions of

89/336/EEC	Electromagnetic Compatibility Directive.
73/023/EEC	Low Voltage Directive.



Dr. S. E. Ormrod, Technical Director

14.9.99, Crawley

Date and Place

CONTENTS

Section	Title	Page
1	INTRODUCTION	1-1
1.1	Scope and definitions	1-1
1.2	Features of the M150	1-2
1.3	Principle of operation	1-2
1.3.1	Normal operation	1-2
1.3.2	Pressure-switch and bypass-valve operation	1-4
1.4	Heater unit and cartridge	1-8
1.5	Control unit connections	1-10
1.6	Controls and displays	1-10
1.6.1	Introduction	1-10
1.6.2	Status display	1-12
1.6.3	Cartridge temperature controllers	1-16
1.6.4	Heater controllers	1-17
1.7	Electrical supply and compressed gas supply failure	1-18
1.8	Phase balance monitor (M150E only)	1-18
1.9	Accessories	1-18
1.9.1	Introduction	1-18
1.9.2	Cartridge change cart accessory	1-18
1.10	Ordering options	1-20
2	TECHNICAL DATA	2-1
2.1	Operating conditions and performance	2-1
2.2	Mechanical data	2-1
2.3	Electrical data	2-1
2.4	Gas supplies	2-2
2.5	Manufacturing materials	2-2
2.6	Connections	2-2
2.7	Ordering information	2-5
3	INSTALLATION	3-1
3.1	Safety	3-1
3.2	System design	3-1
3.3	Unpack and inspect	3-2
3.4	Locate the M150 enclosure	3-6
3.5	Remove the transit bracket and level the enclosure	3-6
3.6	Connect the remote fault outputs (if required)	3-7
3.7	Connect the gas supplies	3-8
3.8	Connect the electrical supply	3-8
3.9	Remove the heater unit from the enclosure	3-8
3.10	Connect the M150 inlet and outlet	3-10
3.11	Fit a cartridge and refit the heater unit	3-12
3.12	Connect to your air-extraction system	3-12
3.13	Fit the pump exhaust TMS components: optional	3-12
3.14	Fit additional ordering option components (if necessary)	3-13
3.15	Fit other accessories (optional)	3-13

Section	Title	Page
3.16	Leak-test the system	3-13
4	OPERATION	4-1
4.1	Use of the M150 with new process equipment	4-1
4.2	Start-up	4-1
4.3	Cartridge change	4-2
4.4	Fault indications	4-2
4.5	Shut-down	4-3
5	MAINTENANCE	5-1
5.1	Safety	5-1
5.2	Maintenance plan	5-2
5.3	Check the pressure-switch purge and process gas flows	5-2
5.4	Change the cartridge	5-3
5.4.1	Cartridge life	5-3
5.4.2	Cartridge change log cards	5-3
5.4.3	Remove the heater unit from the enclosure	5-4
5.4.4	Remove the used cartridge	5-8
5.4.5	Fit the new cartridge	5-11
5.4.6	Refit the heater unit in the enclosure	5-12
5.4.7	Switch on the M150 again	5-13
5.5	Check the operation of the pressure-switches	5-13
5.6	Check the composition of the outlet gas (optional)	5-13
5.7	Replace the thermal fuses	5-13
5.7.1	Replace the enclosure thermal fuse	5-13
5.7.2	Replace the heater unit thermal fuse	5-14
5.8	Adjust the cartridge temperature controllers	5-14
5.8.1	Introduction	5-14
5.8.2	Unlock the controller	5-14
5.8.3	Change the default maximum temperature	5-16
5.8.4	Change the temperature set point	5-16
5.8.5	Lock the controller	5-17
5.8.6	Re-enter the operating parameters into the controller	5-17
5.9	Adjust the heater controllers	5-18
5.9.1	Introduction	5-18
5.9.2	Change the heater temperature setting	5-18
5.10	Replace the flexible bellows	5-19
5.11	Fault finding	5-20
5.11.1	General	5-20
5.11.2	Heater and solid-state relay fault finding	5-26
6	STORAGE AND DISPOSAL	6-1
6.1	Storage	6-1
6.2	Disposal	6-1
6.2.1	General	6-1
6.2.2	Disposal of used cartridges	6-2

Section	Title	Page
7	SERVICE, SPARES AND ACCESSORIES	7-1
7.1	Introduction	7-1
7.2	Service	7-1
7.3	Spares	7-1
7.3.1	Cartridges	7-1
7.3.2	Recommended M150 spares	7-2
7.3.3	Other spares	7-2
7.3.4	End-point detector spares	7-3
7.4	Accessories	7-3
7.4.1	Cartridge change cart	7-3
7.4.2	Valve locking kit	7-3
7.4.3	Exhaust Gas Sample Kit	7-3
7.4.4	Remote Display	7-4

APPENDICES

A1	CARTRIDGE HANDLING: SINGLE PERSON OPERATION	A1-1
A1.1	Introduction	A1-1
A1.2	Fit a new cartridge into a heater unit	A1-1
A1.3	Remove a used cartridge from a heater unit	A1-2
A2	END-POINT DETECTOR ORDERING OPTION	A2-1
A2.1	Description	A2-1
A2.1.1	Principle of operation	A2-1
A2.1.2	Applications	A2-1
A2.2	Technical data	A2-1
A2.3	Additional installation requirements	A2-2
A2.3.1	Unpack and inspect	A2-2
A2.3.2	Fill and fit the end-point detector bottle	A2-2
A2.4	Operation	A2-2
A2.5	Maintenance	A2-4
A2.5.1	Refill the end-point detector bottle	A2-4
A2.5.2	Replace the end-point sample pump	A2-5
A2.5.3	Fault finding	A2-6
A3	TMS (TEMPERATURE MANAGEMENT SYSTEM) ORDERING OPTION	A3-1
A3.1	Description	A3-1
A3.1.1	Principle of operation	A3-1
A3.1.2	Installation details	A3-1
A3.2	Technical data	A3-1
A3.3	Additional installation requirements	A3-2
A3.3.1	Unpack and inspect	A3-2
A3.3.2	Fit the pump exhaust TMS components	A3-2
A3.4	Operation	A3-2
A3.5	Maintenance	A3-4
A3.5.1	Re-enter the operating parameters into the TMS temperature controller	A3-4

Section	Title	Page
A3.5.2	Fault finding	A3-5
A4	LEAK TEST ORDERING OPTION	A4-1
A4.1	Description	A4-1
A4.2	Technical data	A4-1
A4.3	Operation	A4-2
A4.3.1	Start-up	A4-2
A4.3.2	Restart after cartridge change	A4-4
A4.4	Maintenance	A4-4
A4.4.1	Regular maintenance	A4-4
A4.4.2	Fault finding	A4-5
A5	AIR TUYERE (FOR ARSINE AND AIR INJECTION APPLICATIONS) ORDERING OPTIONS	A5-1
A5.1	Description	A5-1
A5.1.1	Introduction	A5-1
A5.1.2	Installation details	A5-1
A5.2	Technical data	A5-1
A5.3	Additional installation requirements	A5-2
A5.3.1	Unpack and inspect	A5-2
A5.3.2	Connect the compressed air supply	A5-2
A5.3.3	Connect the air tuyere pipeline to the cartridge	A5-2
A5.3.4	Adjust the compressed air flow	A5-4
A5.4	Operation	A5-4
A5.5	Maintenance	A5-4
A5.5.1	Check the compressed air flow rate	A5-4
A5.5.2	Change a cartridge (standard air tuyere option)	A5-4
A5.5.3	Change the cartridge (arsine air tuyere option)	A5-5
A5.5.4	Fault finding	A5-5
A5.6	Disposal of used cartridges	A5-5
A6	INLET PRESSURE DISPLAY ORDERING OPTION	A6-1
A6.1	Description	A6-1
A6.1.1	Principle of operation	A6-1
A6.1.2	Installation details	A6-1
A6.2	Technical data	A6-1
A6.3	Operation	A6-1
A6.4	Maintenance	A6-1
A6.4.1	Re-enter the operating parameters into the inlet pressure display	A6-1
A6.4.2	Fault finding	A6-4
A7	AUDIBLE ALARM ORDERING OPTION	A7-1
A7.1	Description	A7-1
A7.2	Technical data	A7-1
A7.3	Additional installation requirements	A7-1
A7.3.1	Unpack and inspect	A7-1
A7.3.2	Fit the audible alarm	A7-2

Section	Title	Page
A7.3.3	Adjust the alarm on and cancel timers (optional)	A7-2
A7.4	Operation	A7-2
A7.5	Maintenance	A7-4
A7.5.1	Regular maintenance	A7-4
A7.5.2	Fault finding	A7-4
A8	PREHEAT STATION ORDERING OPTION	A8-1
A8.1	Introduction	A8-1
A8.1.1	Description	A8-1
A8.1.2	Control unit configuration	A8-1
A8.1.3	Status display	A8-3
A8.2	Technical data	A8-4
A8.3	Installation	A8-4
A8.4	Operation	A8-6
A8.4.1	Start-up	A8-6
A8.4.2	Remove the heater unit and exhausted cartridge from the M150 GRC	A8-6
A8.4.3	Remove the heater unit from the Preheat Station and fit it to the M150 GRC	A8-7
A8.4.4	Fit a new cartridge to the heater unit and refit in the Preheat Station	A8-8
A8.5	Maintenance	A8-8
A8.5.1	Maintenance plan	A8-8
A8.5.2	Check the nitrogen gas flow	A8-8
A8.5.3	Fault finding	A8-8
A9	REMOTE DISPLAY ACCESSORY	A9-1
A9.1	Description	A9-1
A9.2	Installation	A9-1
A9.2.1	Fit the Remote Display	A9-1
A9.2.2	Connect to an alarm beacon (optional)	A9-1
A9.3	Regular maintenance	A9-1
A10	CONVERSION TABLES	A10-1
	GRC APPLICATION FORM (Form GRC1)	
	GRC INSTALLATION APPLICATION FORM (Form GRC2)	
	GRC CARTRIDGE USE RECORD (Form GRC3)	
	GRC WAFER/EVC TREATMENT RECORD (Form GRC4)	
	GRC REGULAR CHECKSHEET (Form GRC5)	
	RETURN OF BOC EDWARDS EQUIPMENT	

Illustrations

Figure	Title	Page
1-1	Components of the M150	1-3
1-2	Schematic diagram of the M150 process system	1-5
1-3	M150 enclosure	1-6
1-4	Cartridge and heater unit (not to scale)	1-9
1-5	Control panel	1-11
1-6	Control panel status display	1-13
1-7	Cartridge temperature controller	1-16
1-8	Heater controller	1-17
1-9	Cartridge change cart	1-19
2-1	M150 enclosure dimensions (mm)	2-3
2-2	M150 connections dimensions (mm)	2-4
3-1	Remove the transit bracket and support	3-4
3-2	Services connections and interior of the control unit	3-9
3-3	Inlet and outlet seal plates	3-10
3-4	Typical installation configuration	3-11
5-1	Disconnect the heater unit from the enclosure	5-5
5-2	Connect or disconnect the thermocouple connectors	5-6
5-3	Remove the heater unit from the enclosure	5-7
5-4	Prepare to remove the cartridge	5-9
5-5	Remove the used cartridge	5-10
5-6	Thermal fuses	5-15
A2-1	End-point detector components	A2-3
A3-1	TMS components	A3-3
A4-1	Leak test components	A4-3
A5-1	Air tuyere components in the M150 enclosure	A5-3
A6-1	Inlet pressure display components	A6-3
A7-1	Fit the audible alarm	A7-3
A8-1	Components of the Preheat Station	A8-2
A8-2	Control panel status display	A8-5
A9-1	Fit the Remote Display	A9-2

Tables

Table	Title	Page
1-1	Status display LEDs	1-14
3-1	Checklist of enclosure package components	3-3
3-2	Remote fault connector pins	3-7
5-1	Maintenance plan	5-2
5-2	Cartridge temperature controller operating parameters	5-19
5-3	Fault finding	5-21
5-4	Heater resistances	5-26
A2-1	Additional end-point detector components	A2-2
A2-2	End-point detector fault finding	A2-6
A3-1	Additional TMS components	A3-2
A3-2	TMS temperature controller operating parameters	A3-4
A3-3	TMS fault finding	A3-5
A4-1	Leak test fault finding	A4-5
A5-1	Additional air tuyere components	A5-2
A5-2	Air tuyere fault finding	A5-6
A6-1	Inlet pressure display operating parameters	A6-2
A6-2	Inlet pressure display fault finding	A6-4
A7-1	Audible alarm components	A7-1
A7-2	Audible alarm fault finding	A7-4
A8-1	Status display LEDs	A8-3
A8-2	Maintenance plan	A8-8
A8-3	Preheat Station fault finding	A8-9
A10-1	Volumetric flow rate unit conversions	A10-1
A10-2	Linear unit conversions	A10-1
A10-3	Temperature conversions	A10-1
A10-4	Pressure unit conversions	A10-2

(This page deliberately left blank)

1 INTRODUCTION

1.1 Scope and definitions

This manual provides installation, operation and maintenance instructions for the BOC Edwards M150 GRC (Gas Reactor Column), abbreviated to M150 in the remainder of this manual. You must use the M150 as specified in this manual.

Read this manual before you install and operate the M150. Important safety information is highlighted as WARNING and CAUTION instructions; you must obey these instructions. The use of WARNINGS and CAUTIONS is defined below.

WARNING

Warnings are given where failure to observe the instruction could result in injury or death to people.

CAUTION

Cautions are given where failure to observe the instruction could result in damage to the equipment, associated equipment and process.

Throughout this manual, page, figure and table numbers are in the form 'S-N', where 'S' specifies the section or appendix, and 'N' specifies the page, figure or table within the section or appendix.

The units used throughout this manual conform to the SI international system of units of measurement. However, wherever nitrogen flow rates are specified, the term 'slm' is used to mean 'standard l.min⁻¹', and the term 'slh' is used to mean 'standard l.h⁻¹'; these are flows of 1 l.min⁻¹ or 1 l.h⁻¹ at an ambient temperature of 0 °C and a pressure of 1013 mbar (1.013 x 10⁵ Pa).

The following symbols appear on the M150:



Caution - refer to accompanying documents.



Caution - risk of electric shock.



Protective earth (ground) terminal.

1.2 Features of the M150

Notes: The M150 is not a dust scrubber. Although the M150 will trap dust in the cartridge, it cannot remove all dust from the process exhaust gases.

The M150 can be supplied with a number of ordering options fitted: refer to Section 1.10.

The M150 is designed to treat the process exhaust gases from a wide range of process applications.

Refer to Figure 1-1. The M150 has a ventilated enclosure (4) with a control unit (1) and a lower control panel (7). A heater unit (3) with a replaceable cartridge fits in the enclosure. During normal operation, the cartridge is heated and the exhaust gases pass through the cartridge. The cartridge contains chemical reactants which convert the toxic and corrosive exhaust gases into inert, inorganic non-toxic products which remain in the cartridge.

The heater unit and the connecting pipelines are fully enclosed by the ventilated enclosure. This prevents accidental contact with hot components during normal operation, and provides containment to protect against accidental leakage of process gases.

Before you use the M150, ensure that you have obtained advice from BOC Edwards or your supplier on the suitability of the M150 (and the cartridge type) for your process application. BOC Edwards Application Data Sheet P12-1 (available on request) provides application information for the M150. Use the GRC Application Form (form GRC1, included at the end of this manual) to request BOC Edwards recommendations for your application.

1.3 Principle of operation

1.3.1 Normal operation

In the following description, refer to Figure 1-2 which shows a schematic diagram of the M150 process system.

The outlet of your pumping system is connected directly to the inlet of the M150 (9). With the bypass-valve (10) closed and the cartridge inlet isolation-valve (8) open, the gases from the pumping system pass through the cartridge (6). The cartridge is filled with a mixture of solid reactants. These react with the gases to produce non-toxic, inorganic solid by-products.

The heater unit (5) is a stainless steel enclosure into which the cartridge is fitted. Five heaters are clamped around the steel enclosure and these heaters maintain the reactants in the cartridge at a temperature which provides a sufficient speed of reaction. The treated gas passes from the cartridge through the cartridge outlet isolation-valve (3), through the M150 outlet (1) and into your exhaust-extraction system.

A cartridge reaches the end of its operational life in one of two ways:

- When the cartridge reactants are exhausted and so untreated exhaust gases pass through the cartridge.
- When solid reaction deposits in the cartridge create a significant back-pressure, as detected by the pressure-switch unit (11), and a warning or alarm is indicated.

(Continued on page 1-4)

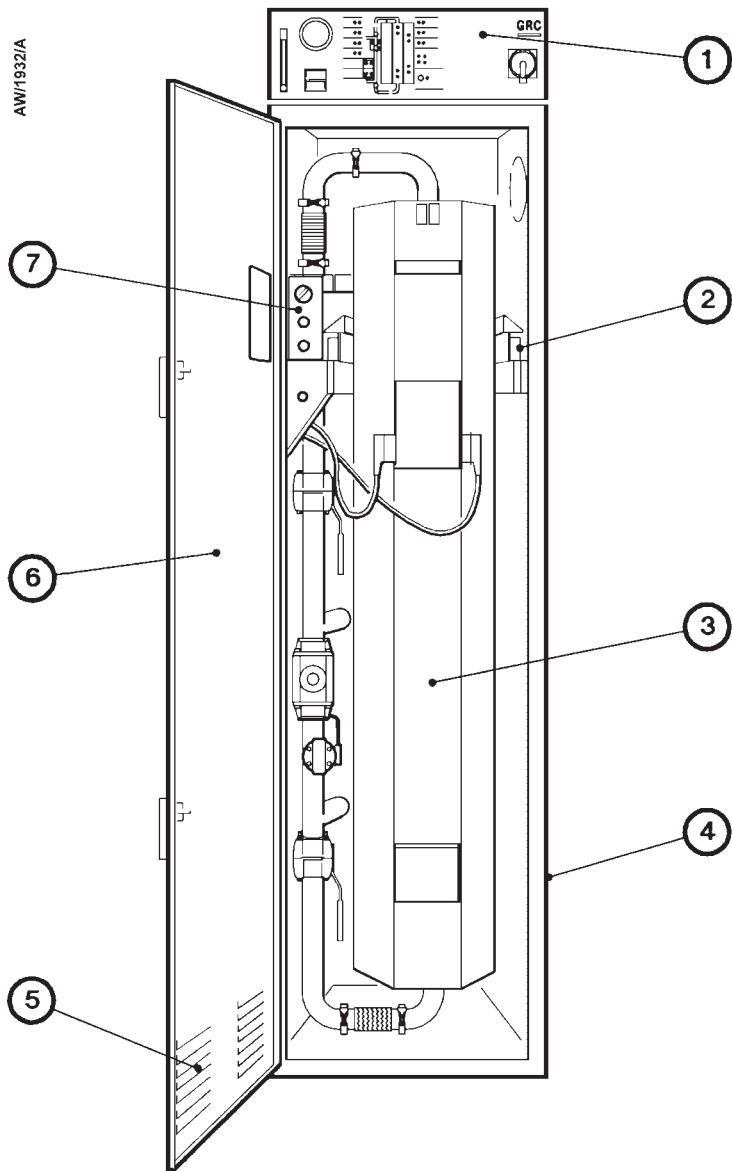

- | | |
|--------------------|------------------------|
| 1. Control unit | 4. Enclosure |
| 2. Roller carriage | 5. Ventilation grills |
| 3. Heater unit | 6. Enclosure door |
| | 7. Lower control panel |

Figure 1-1 - Components of the M150

Cartridge life depends on the quantity of process gases treated. A back-pressure will not always be detected before the cartridge has been exhausted. If your M150 does not have the end-point detector accessory (see Appendix A2), we recommend that you measure the level of process exhaust gases in the outlet from the M150 to determine the life of a cartridge on your process. A sampling port (2) is provided on the M150 outlet for this purpose.

When you want to replace the cartridge, you can open the bypass-valve (10) and close the manually operated cartridge outlet isolation-valve (3) and cartridge inlet isolation-valve (8). The exhaust gases from the pumping system are then isolated from the cartridge and pass directly through the bypass unit and into the exhaust-extraction system; you can therefore replace the cartridge while the pumping system continues to operate.

A blanked off port (7) is provided on the M150 inlet. You can use this port to connect a cartridge inlet-purge supply (see Section 3.7). You can also use this port to introduce a search gas, so that you can leak-test the system after you have installed the M150.

1.3.2 Pressure-switch and bypass-valve operation

The pressure-switch unit provides a warning pressure output and an alarm pressure output. The control unit monitors these outputs. The outputs are off during normal operation; when the outputs are off, the green warning pressure LED and the green alarm pressure LED on the status display are on and the bypass-valve is closed. The two outputs go on at two different preset pressure levels, as described below.

When the pressure rises to a preset level, the warning pressure output goes on; when the warning pressure output goes on:

- the green warning pressure LED on the status display goes off
- the red warning pressure LED on the status display goes on.

If the pressure continues to increase (for example, if a back-pressure is present in the cartridge, or if one of the pipelines to the cartridge or pressure-switches or downstream of the M150 is blocked), the alarm pressure output goes on; when the alarm pressure output goes on:

- the green alarm pressure LED on the status display goes off
- the red alarm pressure LED on the status display goes on
- the bypass-valve opens, the green bypass-valve LED on the status display goes off and the red bypass-valve LED goes on
- the alarm beacon flashes.

At a preset interval after the bypass-valve has opened, the control unit will close the bypass-valve again; this interval is determined by a timer in the control unit. If the pressure has fallen below the alarm pressure level (for example, if the high pressure was due to a transient pressure surge during pump-down), the alarm beacon goes off and the M150 will continue to operate normally. If the pressure has not fallen, the bypass-valve will open again; the timer in the control unit will then start again. This cycle is repeated until you take action to rectify the cause of the high pressure.

(Continued on page 1-8)

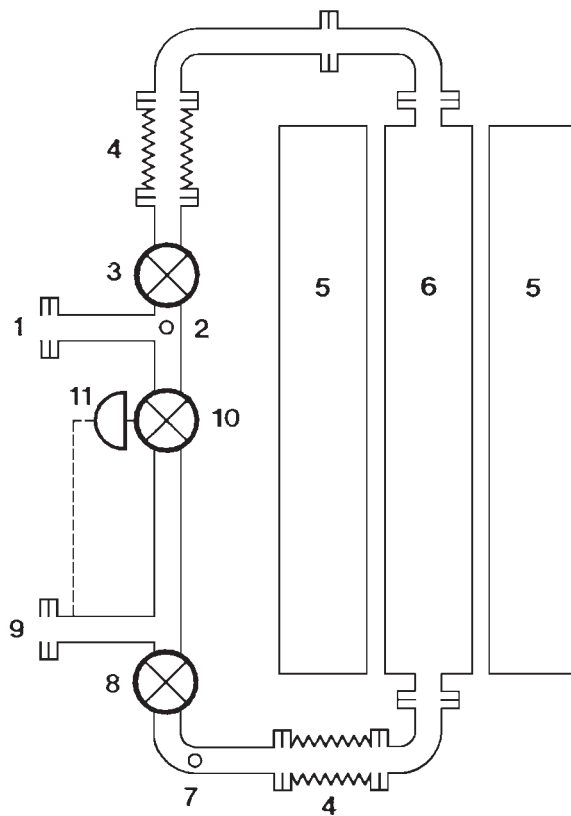

AW/1901/A

1. M150 outlet
2. Sample port
3. Manually operated cartridge outlet isolation-valve
4. Flexible bellows
5. Heater unit
6. Cartridge
7. Cartridge inlet purge supply connector
8. Manually operated cartridge inlet isolation-valve
9. M150 inlet
10. Bypass-valve
11. Pressure-switch unit

Figure 1-2 - Schematic diagram of the M150 process system

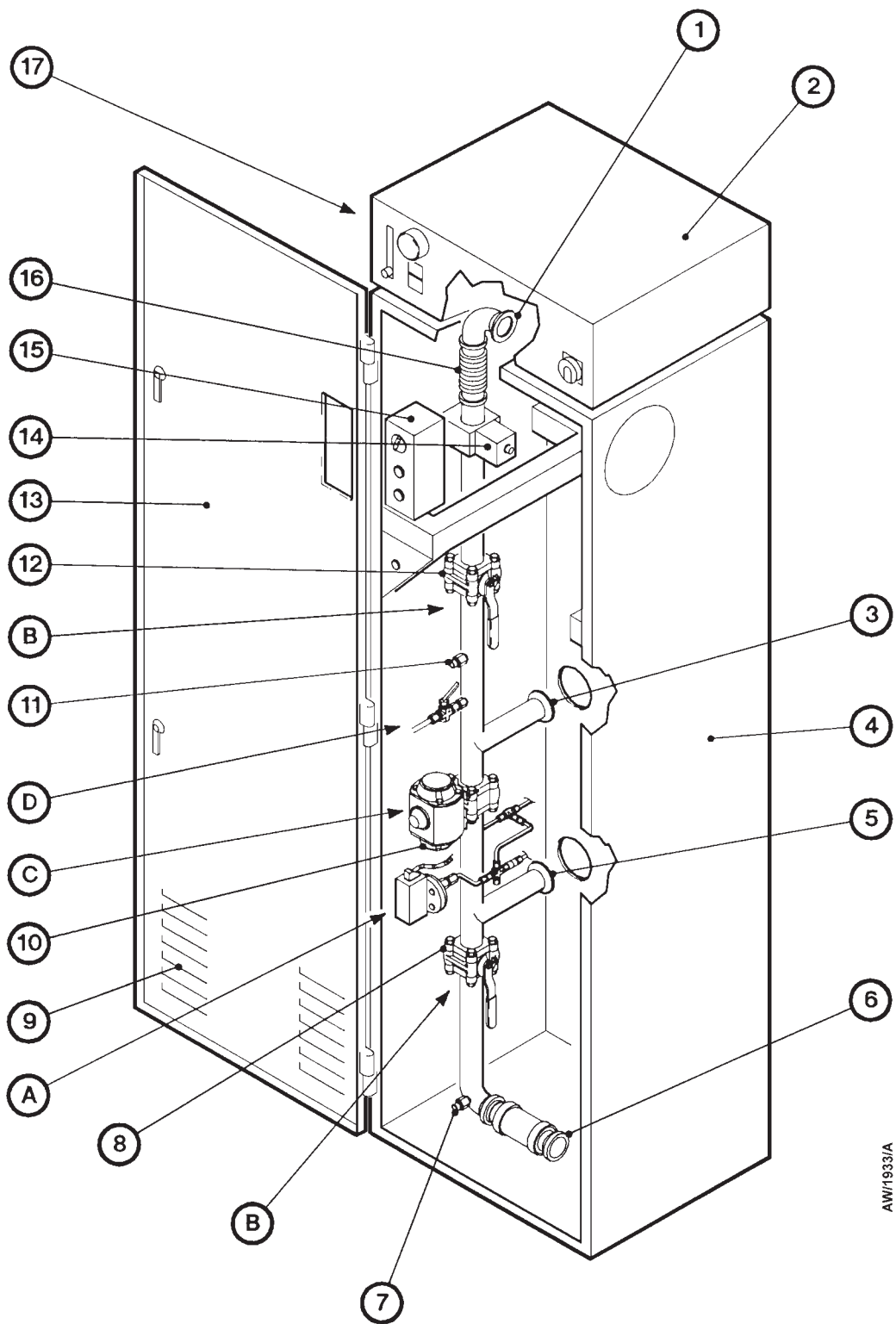
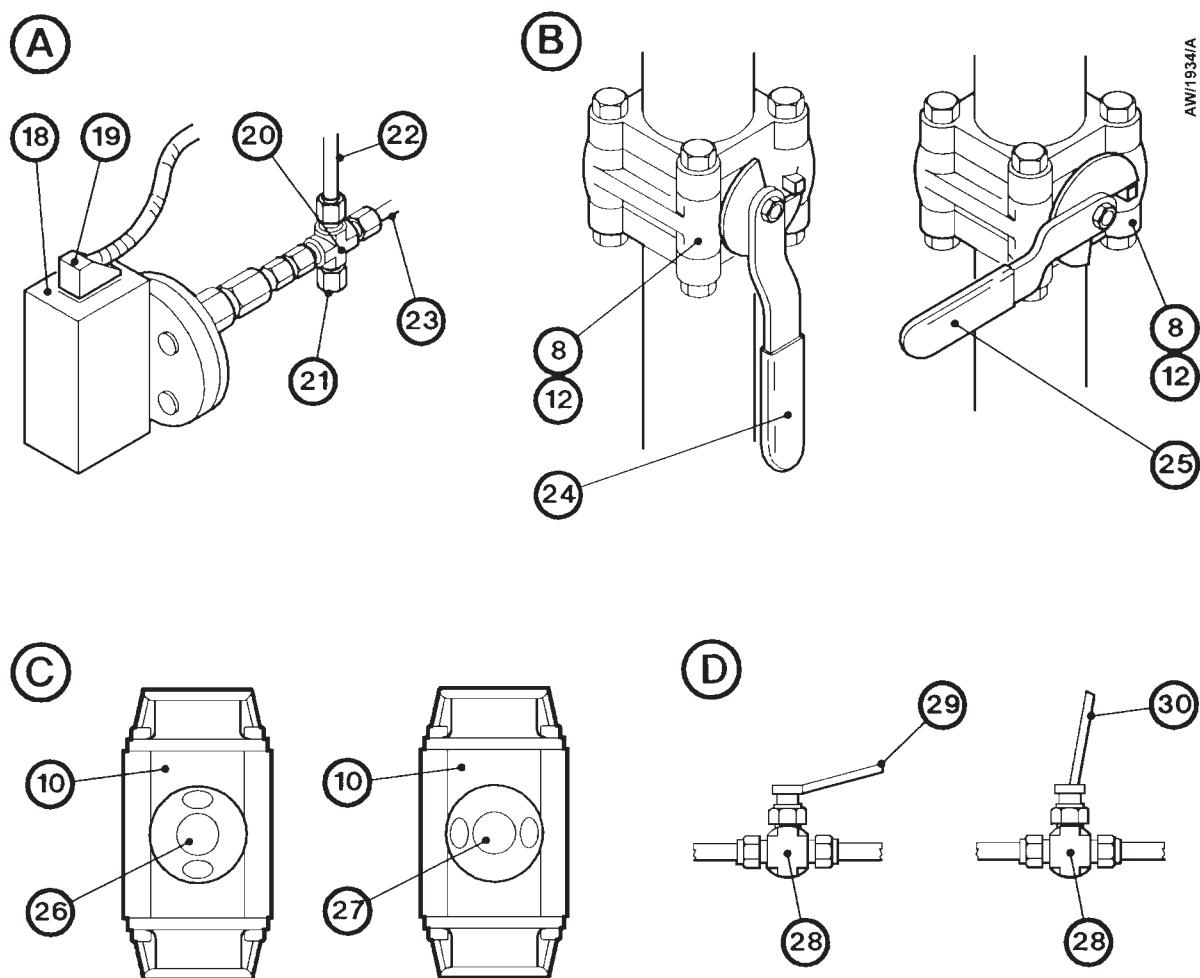

Figure 1-3 - M150 enclosure: sheet 1 of 2



- | | |
|---|--|
| <ol style="list-style-type: none"> 1. Cartridge outlet pipeline 2. Control unit 3. M150 outlet 4. Enclosure 5. M150 inlet 6. Cartridge inlet pipeline 7. Cartridge inlet purge connector 8. Cartridge inlet isolation-valve 9. Ventilation grill 10. Bypass-valve 11. Sample port (blanked) 12. Cartridge outlet isolation-valve 13. Enclosure door 14. Heater unit solenoid-catch 15. Lower control panel | <ol style="list-style-type: none"> 16. Flexible bellows (cartridge outlet pipeline) 17. Rating plate (on side of enclosure) 18. Pressure-switch unit 19. Pressure-switch connector 20. Swagelok cross-connector 21. Pressure gauge port (blanked) 22. Pressure-switch pipeline 23. Purge supply pipeline 24. Isolation-valve handle (open) 25. Isolation-valve handle (closed) 26. Position indicator (valve open) 27. Position indicator (valve closed) 28. Sample valve 29. Valve handle (closed) 30. Valve handle (open) |
|---|--|

Figure 1-3 - M150 enclosure: sheet 2 of 2

As supplied, the timer in the control unit is preset to a time interval suitable for your process application.

Once on, the red alarm pressure LED will remain latched on, even if the bypass-valve closes again (and the green bypass-valve LED goes on) and no high pressure is detected.

The alarm pressure LED remains on so that the operator has an indication that the bypass-valve has opened because of high pressure; the operator may not have noticed the valve open at the time. The Reset button is used to switch off the alarm pressure LED (see section 1.6.1).

As supplied, the pressure-switch unit is factory set to operate at recommended pressures.

Refer to Figure 1-3. The pressure-switch unit has a nitrogen purge pipe (23). The nitrogen purge flow helps prevent blockage of the pipeline to the pressure-switch unit by deposits from the process gases. If a blockage occurs, the pressure of the nitrogen purge supply will cause the pressure-switch to operate as described above.

If necessary (that is, if the pressure-switch goes out of adjustment), you can connect a pressure gauge kit (see Section 7.3.3) to the blanked-off port (21), so that you can adjust the pressure at which the warning pressure output will go on (refer to Section 5.5).

1.4 Heater unit and cartridge

The M150 heater unit rests on roller carriages (Figure 1-1, item 2) in the enclosure so that you can easily move the unit onto the cartridge change cart to change a used cartridge (see Section 5.4).

Refer to Figure 1-4. During operation, the cartridge is maintained at operational temperature by the five heaters (4, 5, 7, 8, 9) in the heater unit (10). The upper zone of the cartridge (6) is heated by three heaters (7, 8, 9). The other two heaters (4, 5) heat the lower zone of the cartridge.

A thermal fuse at the top of the heater unit protects the heater unit and the cartridge from over-temperature damage.

The cartridge has two thermocouples connected to the cartridge temperature controllers; one thermocouple (2) is in the upper zone of the cartridge, the other thermocouple (3) is in the lower zone. The outputs of these thermocouples are used by the cartridge temperature controllers which control the operation of the heaters to maintain the cartridge at the correct operating temperature (see Section 1.6.3).

Electrical connectors (Figure 5-1, items 2 and 3) on the heater unit allow the unit to be connected to the control unit.

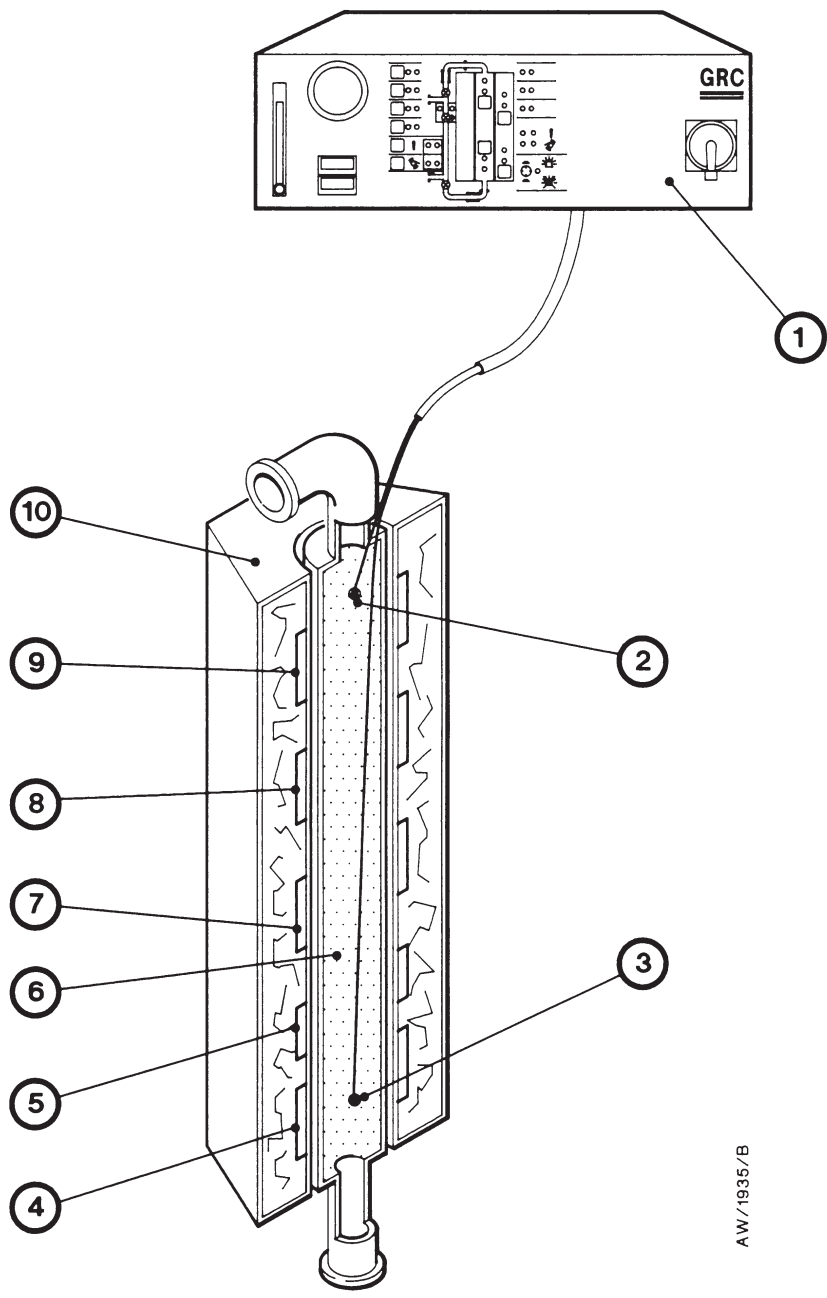

- | | |
|-------------------------|-----------------|
| 1. Control unit | 6. Cartridge |
| 2. Thermocouple (upper) | 7. Heater 3 |
| 3. Thermocouple (lower) | 8. Heater 4 |
| 4. Heater 1 | 9. Heater 5 |
| 5. Heater 2 | 10. Heater unit |

Figure 1-4 - Cartridge and heater unit (not to scale)

1.5 Control unit connections

The top panel of the control unit (shown in Figure 3-2) has the following connectors:

Electrical supply cable gland (11)	To connect the electrical supply to the M150.
Nitrogen supply connector (10)	To connect the nitrogen purge supply to the M150.
Compressed-gas supply connector (9)	To connect the compressed gas supply (for actuation of the bypass-valve) to the M150.
Remote input connector (8)	To (optionally) connect a remote input signal from your control equipment.
Remote fault connector (7)	To connect the remote fault outputs to your process or control equipment (refer to Section 3.6).
Remote display connector (5)	To connect a remote display accessory to the M150 (refer to Section 3.15).

1.6 Controls and displays

1.6.1 Introduction

The control unit has the following controls and displays (refer to Figure 1-5):

Alarm beacon (1)	This flashes when a red alarm LED is on (see Section 1.6.2).
Electrical supply isolator (4)	Use this to switch the M150 on and off.
Cartridge temperature controllers (6, 7)	Use these to control the operation of the heaters; refer to Section 1.6.3.
Status display (2)	The status display shows a schematic display of the M150 process system. LEDs on the schematic display indicate the status of the M150. The status display also indicates faults (refer to Section 5.11).
Pressure-switch purge flow-meter and flow-control valve (9, 8)	Use these to monitor and control the flow rate of purge nitrogen to the pressure-switch unit.

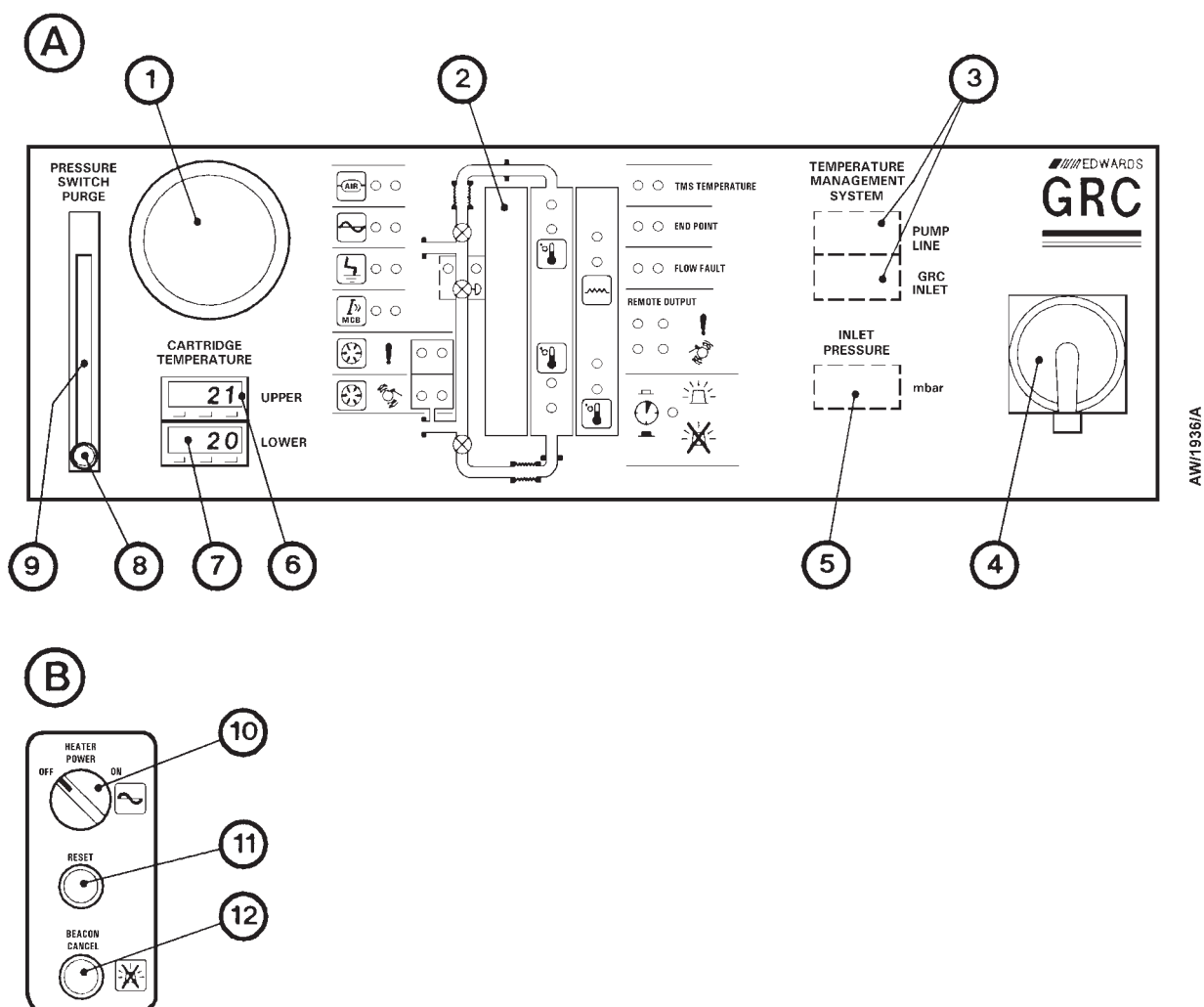

A Control unit
 B Lower control panel

- | | |
|---|---|
| 1. Alarm beacon | 7. Lower cartridge temperature controller |
| 2. Status display | 8. Pressure-switch purge flow-control valve |
| 3. TMS temperature controller positions * | 9. Pressure-switch purge flowmeter |
| 4. Electrical supply isolator | 10. Heater power switch |
| 5. Inlet pressure display position * | 11. Reset button |
| 6. Upper cartridge temperature controller | 12. Beacon cancel button |

* Optional accessories

Figure 1-5 - Control panel

The lower control panel has the following controls:

- | | |
|--------------------------|---|
| Reset button (11) | Use this button to reset the M150 after the electrical supply has been turned off. Also use this button to turn off any red fault LEDs which have been latched on (for example, the red alarm pressure LED) or to switch the alarms on again, after the cancel button has been used to switch the alarms off because of low temperature during warm-up. |
| Cancel button (12) | Press this button during the warm-up period when a new cartridge is heated up, to cancel the remote fault outputs if they are on because of low temperature. |
| Heater power switch (10) | Use this to switch the electrical supplies to the heater unit on and off. |

Refer to Figure 3-2. The inside of the control unit has the following controls:

- | | |
|-------------------------|--|
| Heater controllers (16) | Use these to control the operation of the heaters: refer to Section 1.6.4. |
|-------------------------|--|

1.6.2 Status display

The status display is shown in Figure 1-6. The display has red and green LEDs (see Table 1-1, on page 1-14). In normal operation, only green (status) LEDs should be on; a red (fault) LED indicates a fault condition. The red LEDs go on or flash when a fault is present, however the red alarm pressure LED will continue to flash if an alarm pressure has caused the bypass-valve to open and the bypass-valve has then closed again when the pressure surge has passed (see Section 1.3.2). For a full description of fault finding when a red fault LED goes on or flashes, refer to Section 5.11.

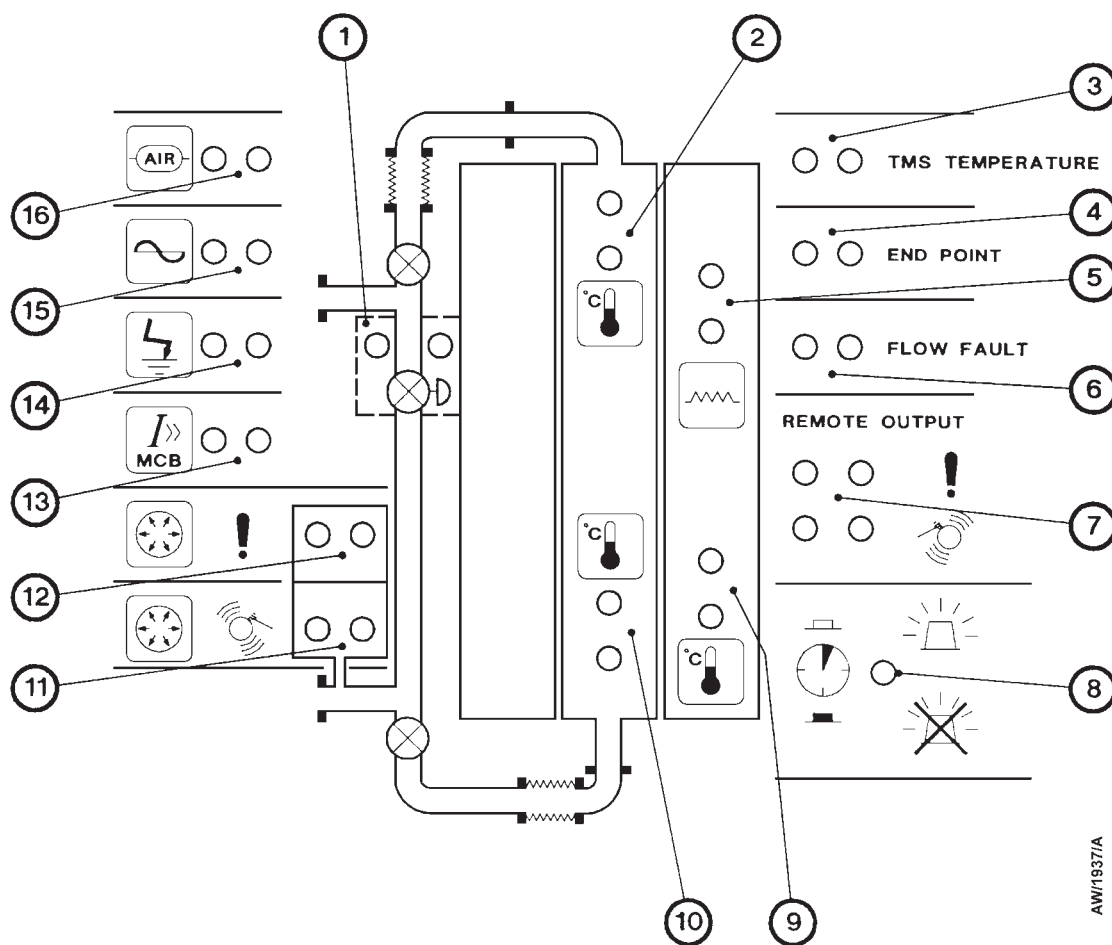

AW1937/A

- | | |
|-------------------------------------|--------------------------------------|
| 1. Bypass-valve LEDs | 9. Lower heater temperature LEDs |
| 2. Upper cartridge temperature LEDs | 10. Lower cartridge temperature LEDs |
| 3. TMS temperature LEDs * | 11. Alarm pressure LEDs |
| 4. End-point detector LEDs * | 12. Warning pressure LEDs |
| 5. Phase balance monitor LEDs † | 13. Circuit breaker LEDs |
| 6. Flow fault LEDs * | 14. Earth leakage trip LEDs # |
| 7. Remote fault output LEDs | 15. Heater power LEDs |
| 8. Timer LED | 16. Compressed gas LEDs |

* Only used if the corresponding ordering option is fitted to the M150

Only used if the corresponding accessory is fitted to the M150

† Used on the M150E only

Figure 1-6 - Control panel status display

Figure 1-6 key	LEDs Name	Meaning
16	Compressed gas	The green LED is on when the pressure of the compressed gas supply is acceptable. The red LED flashes when the pressure of the compressed gas supply is below 2.7 ± 0.2 bar gauge; that is, the pressure is too low to operate the bypass-valve.
15	Heater power	The green LED is on during normal operation. The red LED flashes when the electrical supply to the heaters is interrupted.
14	Earth leakage trip	These LEDs are only used if you have the earth leakage trip accessory in your M150: refer to the instruction manual supplied with the accessory.
13	Circuit breaker	The green LED is on when the M150 is connected to the electrical supply and is switched on. The red LED flashes when the M150 is connected to the electrical supply and the circuit breaker has tripped to shut down the M150.
12	Warning pressure	The green LED is on when the pressure measured by the pressure-switch unit is within acceptable limits. The red LED flashes when the warning pressure level is reached.
11	Alarm pressure	The green LED is on during normal operation. The red LED flashes when the pressure in the pipeline is above the preset alarm level (that is, the pressure-switch unit has set the alarm pressure output on).
10	Lower cartridge temperature	The green LED is on when the cartridge thermocouples indicate that the temperature of the bottom of the cartridge is within acceptable limits. The red LED flashes when the thermocouples indicate that the temperature of the bottom of the cartridge is too high or too low. (Refer to Section 1.4).
9	Lower heater temperature	The green LED is on when the heater thermocouple indicates that the temperature of the single heater in the bottom of the heater unit is in acceptable limits. The red LED flashes when the thermocouple indicates that the temperature of the heater is too low (refer to Section 1.4).
8	Timer	This red LED flashes when the timer to cancel the beacon is operating; that is, the cancel button has been pressed.
7	Remote fault output	The upper and lower green LEDs are on when the M150 is operating correctly. When there is a warning condition, the upper green LED goes off and the upper red LED goes on. When there is an alarm condition, the lower green LED goes off and the lower red LED goes on.

Table 1-1 - Status display LEDs

Figure 1-6 key	LEDs Name	Meaning
6	Flow fault	These LEDs are only used if you have the end point detector ordering option fitted: refer to Appendix A2.
5	Phase balance monitor	These LEDs are only used on the M150E. The green LED is on when the currents (drawn by the upper heaters) on the three phases of the electrical supply are in balance. The red LED flashes when the currents are out of balance: see Section 1.8.
4	End point	These LEDs are only used if you have the end-point detector ordering option fitted: refer to Appendix A2.
3	TMS	These LEDs are only used if you have the TMS ordering option fitted: refer to Appendix A3.
2	Upper cartridge temperature	The green LED is on when the cartridge thermocouples indicate that the temperature of the top of the cartridge is within acceptable limits. The red LED flashes when the thermocouples indicate that the temperature of the top of the cartridge is too high or too low (see Section 1.4).
1	Bypass-valve	The green LED is on when the bypass-valve is closed. The red LED flashes when the bypass-valve is open.

Table 1-1 - Status display LEDs (continued)

1.6.3 Cartridge temperature controllers

Note: The heaters are only switched on by the cartridge temperature controllers if the heater controllers have not switched the heaters off (see Section 1.6.4).

The M150 has two cartridge temperature controllers. One of the two cartridge temperature controllers is shown in Figure 1-7. The two controllers monitor the outputs of the upper and lower cartridge thermocouples to determine the temperature of the cartridge and to switch the heaters on and off to maintain the required temperature. The green heater LED (1) goes on when the controller selects power to be supplied to the cartridge heaters.

The cartridge temperature (in °C) is shown on the controller (2), together with a temperature status indicator (3).

The M150 is supplied with set-points in the temperature controllers preset for your application. If the temperature of the cartridge is too far above or below the preset set-point, the red alarm LED on the appropriate controller (3) goes on. If necessary, you can adjust the temperature set-point: refer to Section 5.9.

The controller will also display error messages (for example, if it is disconnected from the thermocouples): refer to Section 5.11.

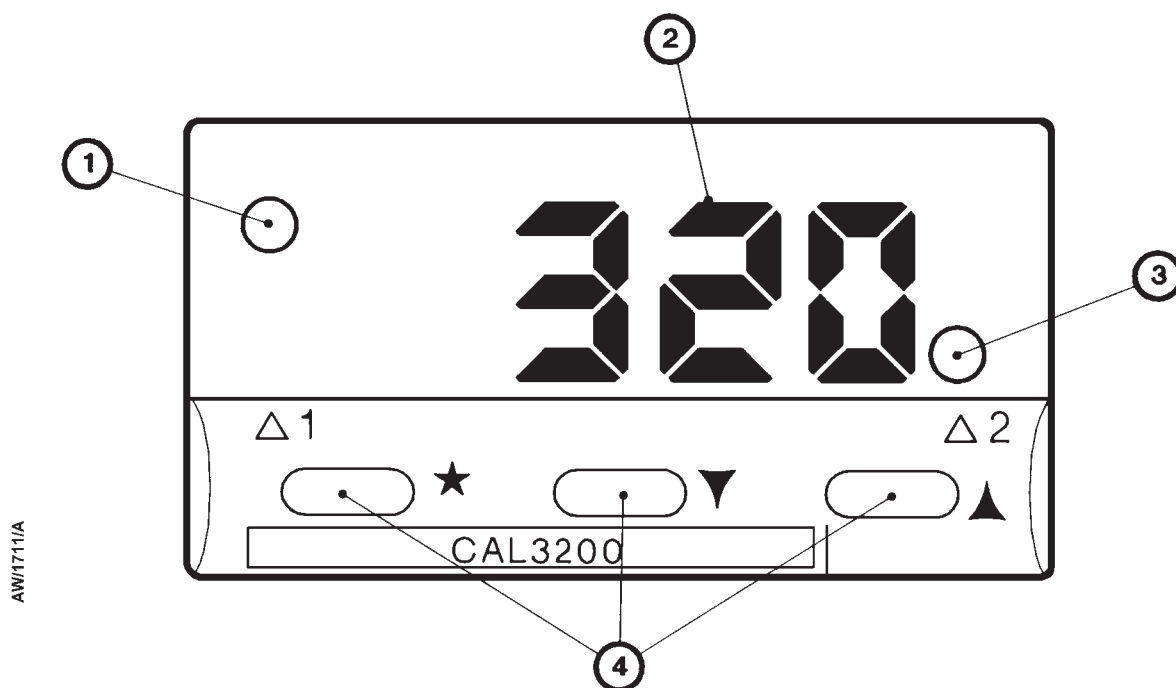

- | | |
|--------------------------|--------------------------|
| 1. Heater LED | 3. Temperature alarm LED |
| 2. Temperature indicator | 4. Control buttons |

Figure 1-7 - Cartridge temperature controller

1.6.4 Heater controllers

The heater controllers are inside the control unit (see Figure 3-2). One of the heater controllers is shown in Figure 1-8. The heater controllers switch the heaters on during warm-up and operate as safety devices to switch the heaters off to prevent over-temperature damage.

During warm-up, it takes up to 90 minutes for heat to penetrate the cartridge and for the outputs of the cartridge thermocouples to cause the cartridge temperature controllers to switch off power to the heaters. Without the heater controllers (which are preset to a temperature close to the required operating temperature of the cartridge), the heaters would overheat during warm-up.

The required operating temperature is shown by the pointer (6) on the temperature display (5). A LED on the controller (2) goes on when the electrical supply to the controller is on; another LED (3) goes on when the heaters are on. When the heater output LED (3) is off, the heaters are switched off (whether the cartridge temperature controllers request the heaters to be switched on or not).

The M150 is supplied with the heater controllers preset to the correct temperature for your application. If necessary, you can adjust the temperature: refer to Section 5.9.2.

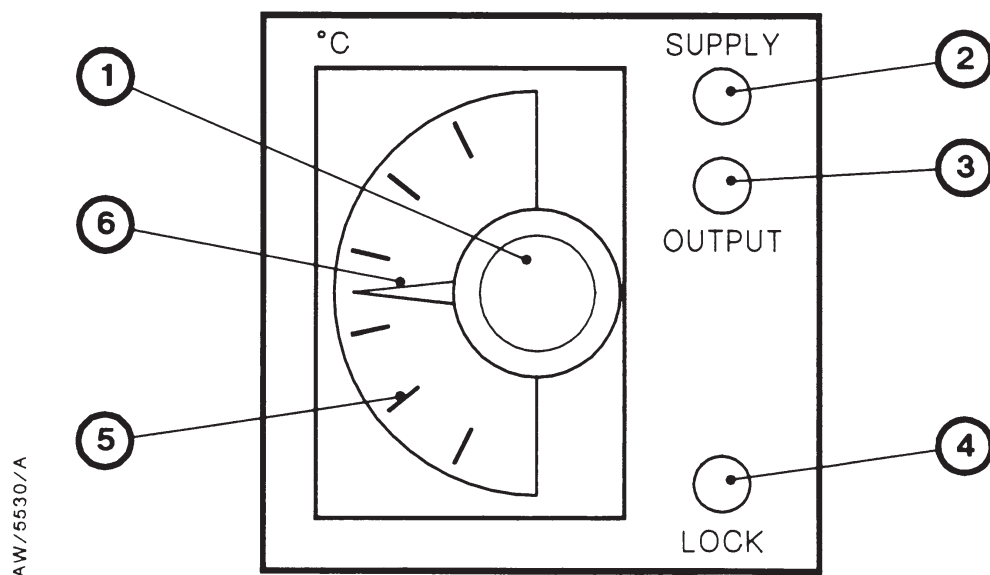

- | | |
|--------------------------------|----------------------|
| 1. Temperature adjuster | 4. Lock |
| 2. Electrical supply LED (red) | 5. Temperature scale |
| 3. Heater output LED (green) | 6. Pointer |

Figure 1-8 - Heater controller

1.7 Electrical supply and compressed gas supply failure

If the compressed gas supply to the M150 fails, the M150 will remain in the same operating condition as it was before the supply failure; that is, the bypass-valve position will not change.

However, note that the M150 cannot respond to a blockage in the exhaust-extraction pipeline or a pressure rise in the M150 pipelines if the compressed gas supply fails when the bypass-valve is closed. You must therefore install suitable safety devices in your system: refer to Section 3.2.

If the electrical supply to the M150 fails, the bypass-valve will open immediately.

1.8 Phase balance monitor (M150E only)

The phase balance monitor is only fitted to the M150E, and monitors the currents drawn by the three upper heaters in the heater unit. If the three phases of the electrical supply are out of balance, this indicates that one or more heaters have failed, that one or more phases of the electrical supply have failed, or that a solid-state relay has failed.

When the monitor detects a phase imbalance, the red phase balance monitor LED on the status display goes on and the EMO circuit is activated to turn off the heaters, open the bypass-valve and flash the alarm beacon.

1.9 Accessories

1.9.1 Introduction

A number of accessories are available for the M150. You can use these accessories to optimise the operation of the M150 for your specific applications. The accessories are listed in Section 7.

Note that you must have at least one cartridge change cart accessory available (see Section 1.9.2) to allow you to change cartridges.

1.9.2 Cartridge change cart accessory

You must have at least one cartridge change cart to allow you to change cartridges; refer to Section 7 for the Item Number of the cartridge change cart.

Refer to Figure 1-9. The cartridge change cart allows you to remove the heater unit from the M150 enclosure, to replace the used cartridge in the heater unit with a new cartridge and to refit the heater unit in the M150 enclosure:

- The cart is used in the upright position (detail A) to remove the heater unit from the enclosure, to move it to the area where you will change the used cartridge and, after you have replaced a cartridge, to refit the heater unit in the enclosure.
- The cart is turned to the horizontal position (detail B) to remove the used cartridge from the heater unit and to fit the new cartridge in the heater unit.

(Continued on page 1-20)

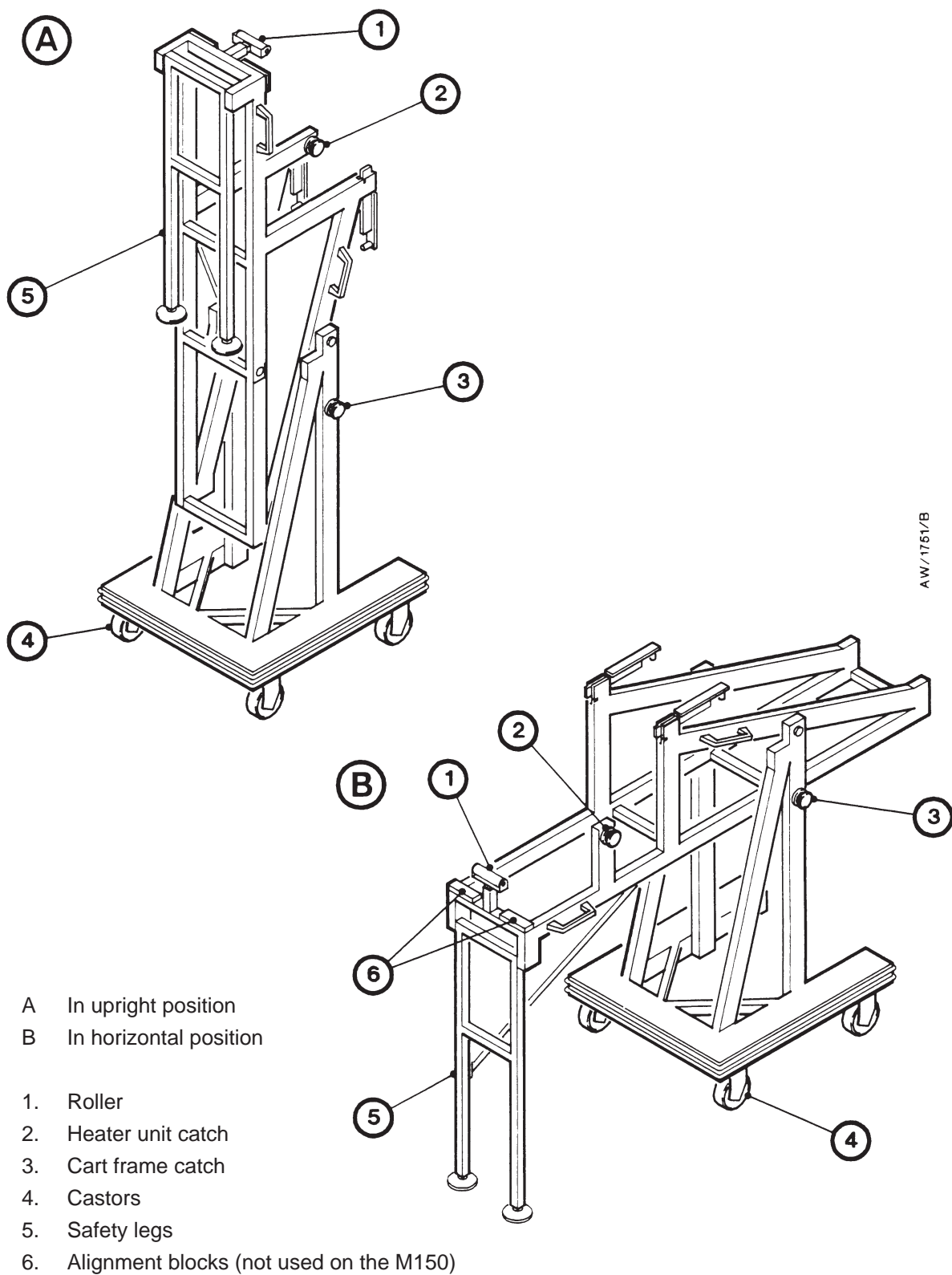

Figure 1-9 - Cartridge change cart

The base of the cart has castors (4) so that you can move the cart. Two of the castors have brakes to secure the cart in its required location.

A catch (3) on the lower frame of the cart secures the upper frame (on which the heater unit rests) in its vertical or horizontal position. When you turn the cart into the horizontal position (as in detail B), the safety legs (5) automatically drop into place to support the upper frame of the cart.

The catch (2) on the upper frame secures the heater unit in place on the cart. The roller (1) supports the end of a cartridge when you fit a new cartridge in the heater unit.

For full instructions on the use of the cart, refer to Section 5.4.

1.10 Ordering options

The M150 can be supplied with a number of ordering options; note that not all of the options may be fitted. The ordering options available are as follows:

End-point detector	When used on certain process applications, this option provides an indication that the cartridge in the M150 is chemically exhausted: refer to Appendix A2.
TMS (Temperature Management System)	This option allows the M150 process pipelines to be heated to reduce the deposition of solids in the pipelines: refer to Appendix A3.
Leak test	This option allows the cartridge and the M150 process pipelines to be automatically leak tested after you have fitted a new cartridge: refer to Appendix A4.
Air tuyere (for arsine and air injection applications)	This option allows you to use the M150 (with C150JV cartridges) on arsine process applications, or to use the M150 (with C150R cartridges) on process applications which require air injection: refer to Appendix A5.
Inlet pressure display	This option allows you to monitor the pressure in the M150 inlet pipeline: refer to Appendix A6.
Audible alarm	This option allows you to hear when an alarm condition exists: refer to Appendix A7.
Preheat Station	When you order this option, the M150 is configured as a Preheat Station, which enables you to preheat M150 cartridges: refer to Appendix A8.

2 TECHNICAL DATA

Note: Refer to Appendices A2 to A8 for additional technical data for ordering options.

2.1 Operating conditions and performance

Total gas flow rate	5 slm (minimum) to 60 slm (maximum)
Time to warm up to operating temperature	approximately 60 to 90 min
Cartridge capacity	Halogen equivalent to 2000-2500 l of chlorine
Operating environment	Suitable for indoor use only
Operating ambient temperature range	5 to 40 °C
Operating ambient humidity range	30 to 95% RH, non condensing
Minimum air-extraction flow rate	200 m ³ h ⁻¹

2.2 Mechanical data

Dimensions	See Figures 2-1 and 2-2
Mass	
Enclosure and control unit	101 kg
Heater unit (without cartridge)	64 kg
C150Y cartridge (unused)	39 kg
Total	204 kg

2.3 Electrical data

Electrical supply	M150E	M150J	M150K/S
Voltage (V a.c.)	380/415	200	208
Number of phases	3	3	3
Frequency (Hz)	50	50/60	60
Current rating per phase (A)	16	22	20
Operating power (all models, when at operating temperature)	0.7 to 1 kW (average) *		
Heater power			
380 V electrical supply	6.45 kW		
200/415 V electrical supply	7.6 kW		
208 V electrical supply	5.7 kW		
Fuse ratings			
Transformer and control	1 A		
Transformer secondary	2.5 A		
Circuit breaker	50 mA		
PCB	2 A		
Thermal fuse fail temperature			
Heater unit	184 °C		
Enclosure	84 °C		

* Dependent on gas flow through the cartridge.

2.4 Gas supplies

Note: Your nitrogen and compressed gas supplies must be clean and dry.

Nitrogen supply	
Supply pressure	1.5 to 2 bar gauge (2.5 to 3 bar absolute)
Pressure-switch purge flow rate	100 slh
Compressed gas supply pressure (nitrogen or compressed air, for actuation of the bypass-valve)	4 to 5 bar gauge (5 to 6 bar absolute)

2.5 Manufacturing materials

Cartridge body	Welded stainless steel
Vacuum pipelines	Stainless steel
Vacuum seals	
'O' rings	Fluoroelastomer
Carriers	Aluminium

2.6 Connections

M150 inlet and outlet	NW40
Cartridge inlet and outlet	NW40
Cartridge inlet purge connector	$\frac{1}{4}$ inch Swagelok
Thermocouple cable connector	Harting 15-way
Heater unit electrical supply connector	Harting 6-way
Pressure-switch cable connector	9-way D-type
Control unit connectors	
Compressed gas supply connector	$\frac{1}{4}$ inch Swagelok
Nitrogen supply connector	$\frac{1}{4}$ inch Swagelok
Remote fault connector	9-way D-type
Remote display connector	25-way D-type
Remote input connector	6-pin DIN

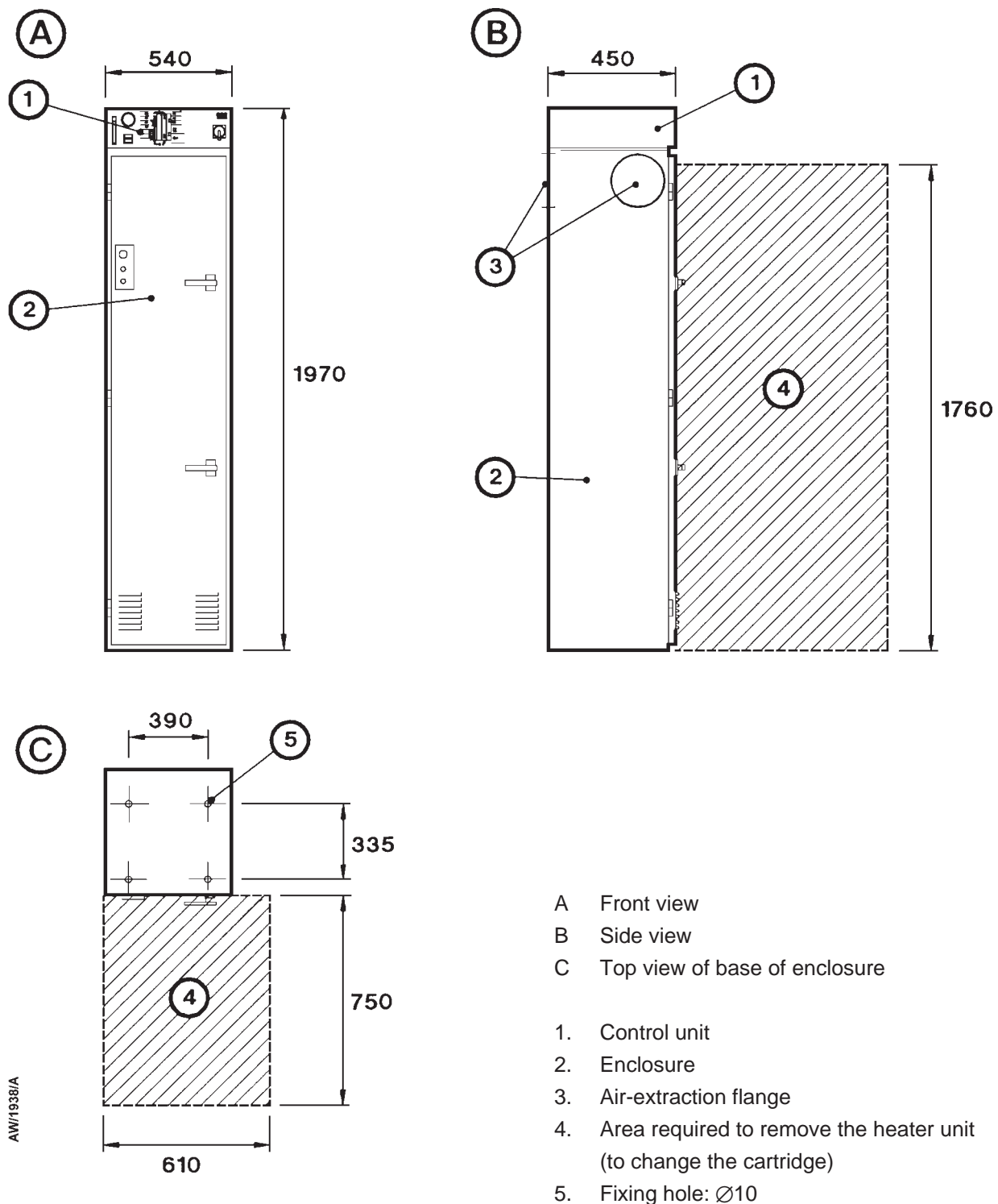

Figure 2-1 - M150 enclosure dimensions (mm)

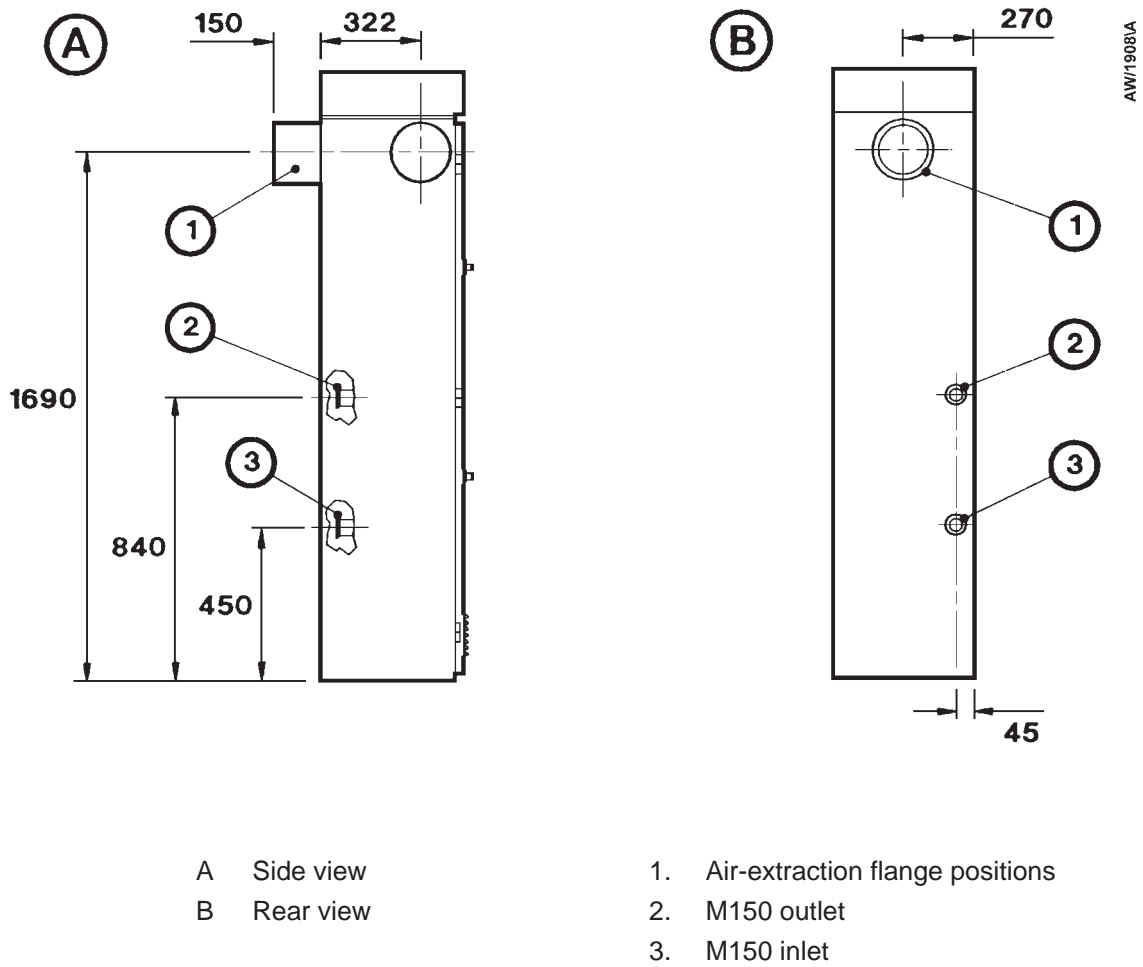
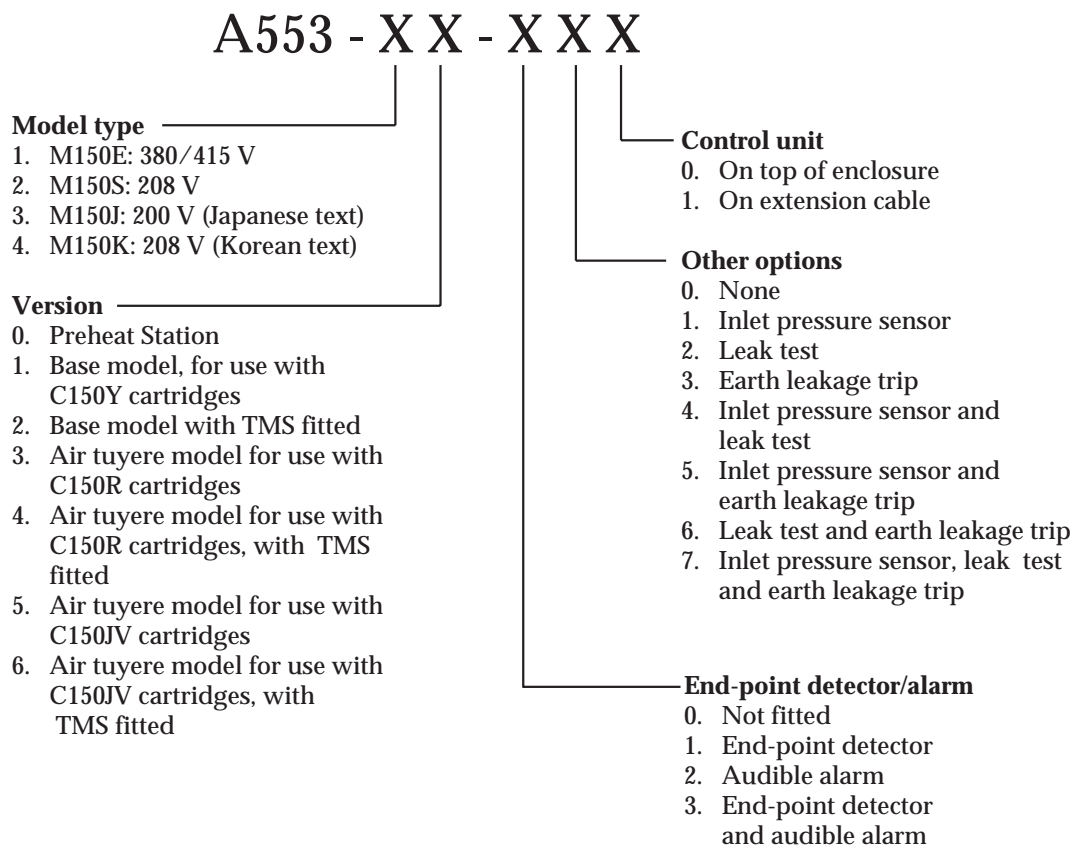

Figure 2-2 - M150 connections dimensions (mm)

2.7 Ordering information

Use the following matrix structure to order an M150 with any required options:



(This page deliberately left blank)

3 INSTALLATION

3.1 Safety

WARNING

Obey the safety instructions given below and take note of appropriate precautions. If you do not, you can cause injury to people and damage to equipment.

- A suitably trained and supervised technician must install the M150.
- Ensure that the installation technician is familiar with and complies with the safety procedures which relate to the products processed by the pumping system.
- Vent and purge the process system before you start any installation work.
- Leak-test the system after installation and maintenance and seal any leaks found to prevent leakage of dangerous substances out of the system and leakage of air into the system.

3.2 System design

WARNING

If the flow of untreated process gas into your exhaust-extraction system may result in a hazardous situation, you must incorporate suitable safety features in your control system.

CAUTION

The design of the exhaust-extraction system must prevent the drainage of moisture or condensation in the exhaust-extraction pipeline into the M150 pipelines. If it does not, the M150 may be blocked or corroded.

Connect the M150 **as close as possible** to the outlet of the pumping system in order to ensure the immediate treatment of the exhaust gases. If the pipeline which connects the pumping system to the M150 is long, there will be a large volume of pipeline in which solids can be deposited, corrosion can occur and flammable exhaust gases may collect.

On certain processes, you will need to heat the pipeline between the pumping system outlet and the M150 inlet to prevent condensation of solids. If you use the M150 in one of these types of processes:

- You should have ordered the TMS (Temperature Management System) option to be factory fitted to your M150 (see Appendix A3).
- You must fit additional TMS components to the pipeline between the pumping system outlet and the M150 inlet (see Section 3.13).

If you wish to connect more than one pumping system to the M150, you must:

- Ensure that the total gas flow does not exceed 60 slm.
- Ensure that it is safe to combine the exhaust gases from the pumping systems; for example, you must not mix silane with air, chlorine or NF₃, or NH₃ with NF₃.
- Obtain advice from BOC Edwards; use form GRC1 at the end of this manual.

You must incorporate suitable safety devices in your control system to:

- Stop the flow of process gas to the M150, if failure of the M150 and the subsequent flow of untreated process gas into the exhaust-extraction system may result in a hazardous situation.
- Switch off the pumping system if a dangerous pressure rise is detected in the pipeline between the pumping system and the M150.

The exhaust gas from the M150 will be hot (approximately 50 °C), but the thermal capacity of the gas is usually low so the gas will cool very quickly. The first two metres of the pipeline from the outlet of the M150 to the exhaust-extraction system must therefore be metal. After two metres, the gas will be at approximately ambient temperature; it is therefore acceptable to use a fibreglass or plastic pipeline.

The design of the exhaust-extraction system must prevent the drainage of moisture or condensation in the exhaust-extraction pipeline into the M150 pipelines. Water above the bypass-valve will enter the M150 pipelines if the bypass-valve is opened and could react with the exhaust gases or deposits in the pipeline and cause blockage or corrosion.

3.3 Unpack and inspect

Note: Cartridges (in packs of two or five) are supplied in a separate package.

M150s are supplied on a large pallet enclosed in protective packaging. Each large pallet holds one or more M150.

Each M150 is mounted on a mini-pallet. The M150 and mini-pallet are on the large pallet and enclosed by packaging which is secured by spring clips and steel bands. Use the following procedure to unpack and inspect the M150.

1. If you have a package with a single M150, use the lifting points provided to turn the package into the upright position. Continue at Step 3.
2. If you have a package with more than one M150, look at the arrow on the 'tip and tell' indicator on the package. If the tip of the arrow is blue, this means that the package has been tilted or laid down during transit and when you inspect the equipment (in Step 10), you should check very carefully that the equipment is not damaged.
3. Remove the three steel bands which secure the package.
4. Use an appropriate tool to release the spring clips and remove the top panel of the package.

5. Release the spring clips on the side panels (remove the centre spring clips last) and remove the side panels.
6. Use a fork-lift truck to remove the M150 (on the mini-pallet) from the large pallet.
7. Remove the plastic wrapping from the M150 and open the door of the enclosure.
8. Remove the transit support (Figure 3-1, item 3) from under the heater unit and remove the package which is behind the transit support.
9. Remove the package from the top of the heater unit.
10. Inspect the enclosure and the components in the packages. If any of the equipment is damaged, notify your supplier and the carrier in writing within three days; state the Item Number and Serial Number of the M150 together with your order number and your supplier's invoice numbers. Retain all packing materials for inspection. Do not use the M150 if it is damaged.
11. Look at the rating plate (Figure 1-3, item 17) and check that the M150 is suitable for use with your electrical supply. Do not continue to install the M150 if it is not suitable for use with your electrical supply.
12. Check that you have received the items listed in Table 3-1. If any of these items is missing, notify your supplier in writing within three days. If the M150 is not to be used immediately, replace the protective covers and packaging. Store the M150 in suitable conditions as described in Section 6.
13. Inspect and check that you have received any additional components supplied for any ordering options: refer to Appendices A2 to A8.

Qty	Description	Check (✓)
1	M150 enclosure (with all pipelines, heaters and control unit)	<input type="checkbox"/>
2	NW40 clamping rings	<input type="checkbox"/>
2	NW40 trapped 'O' rings	<input type="checkbox"/>
1	Cartridge change handle	<input type="checkbox"/>
1	Air-extraction flange	<input type="checkbox"/>
2	Air-extraction leadthrough blanking plates	<input type="checkbox"/>
Fitting-kit, which contains:		
1	Remote fault output connector mating-half	<input type="checkbox"/>
2	Temperature controller hexagonal keys	<input type="checkbox"/>
1	184 °C thermal fuses	<input type="checkbox"/>
1	84 °C thermal fuse	<input type="checkbox"/>
1	1 A fuses	<input type="checkbox"/>
1	2 A fuses	<input type="checkbox"/>
1	2.5 A fuses	<input type="checkbox"/>
1	50 mA fuses	<input type="checkbox"/>
2	Cartridge temperature controller instruction manual	<input type="checkbox"/>
1	Cartridge inlet elbow and braided flexible bellows	<input type="checkbox"/>

Table 3-1 - Checklist of enclosure package components

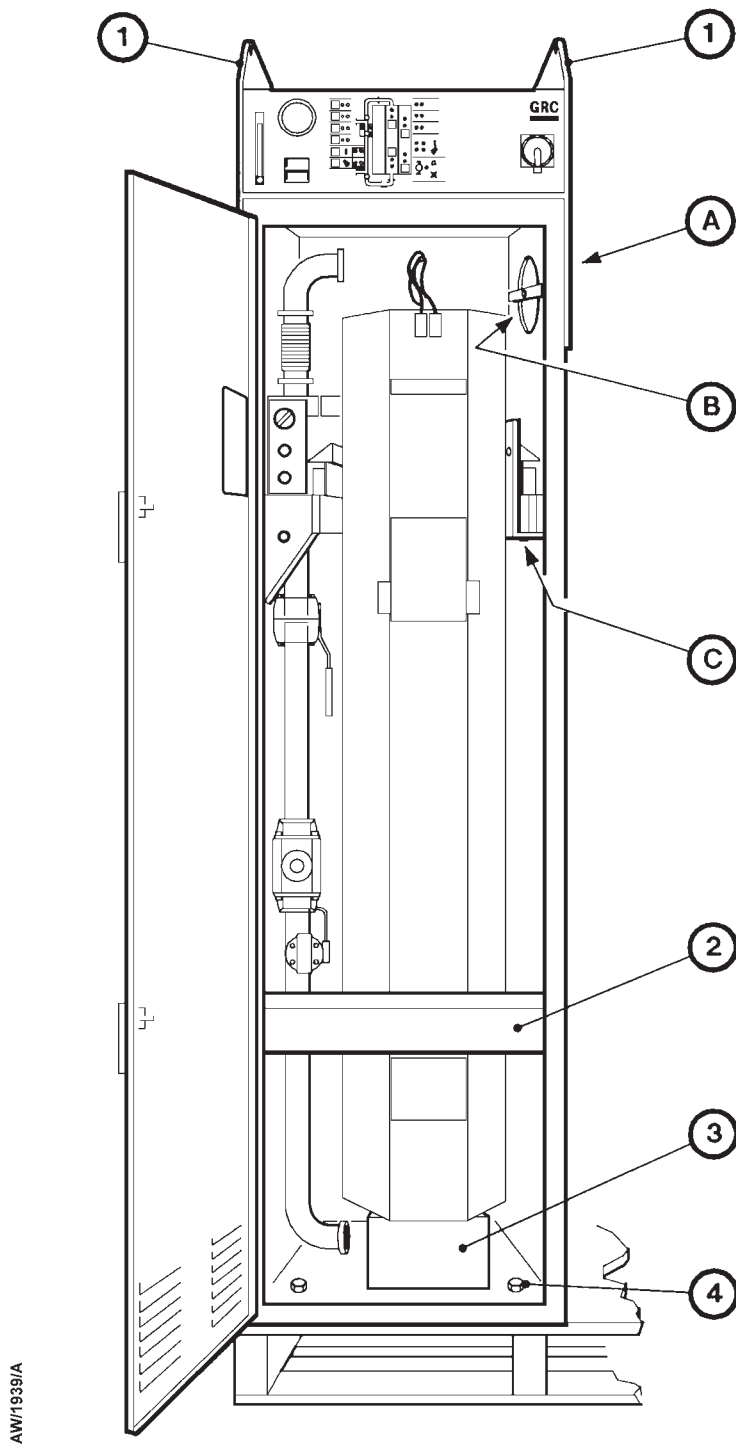
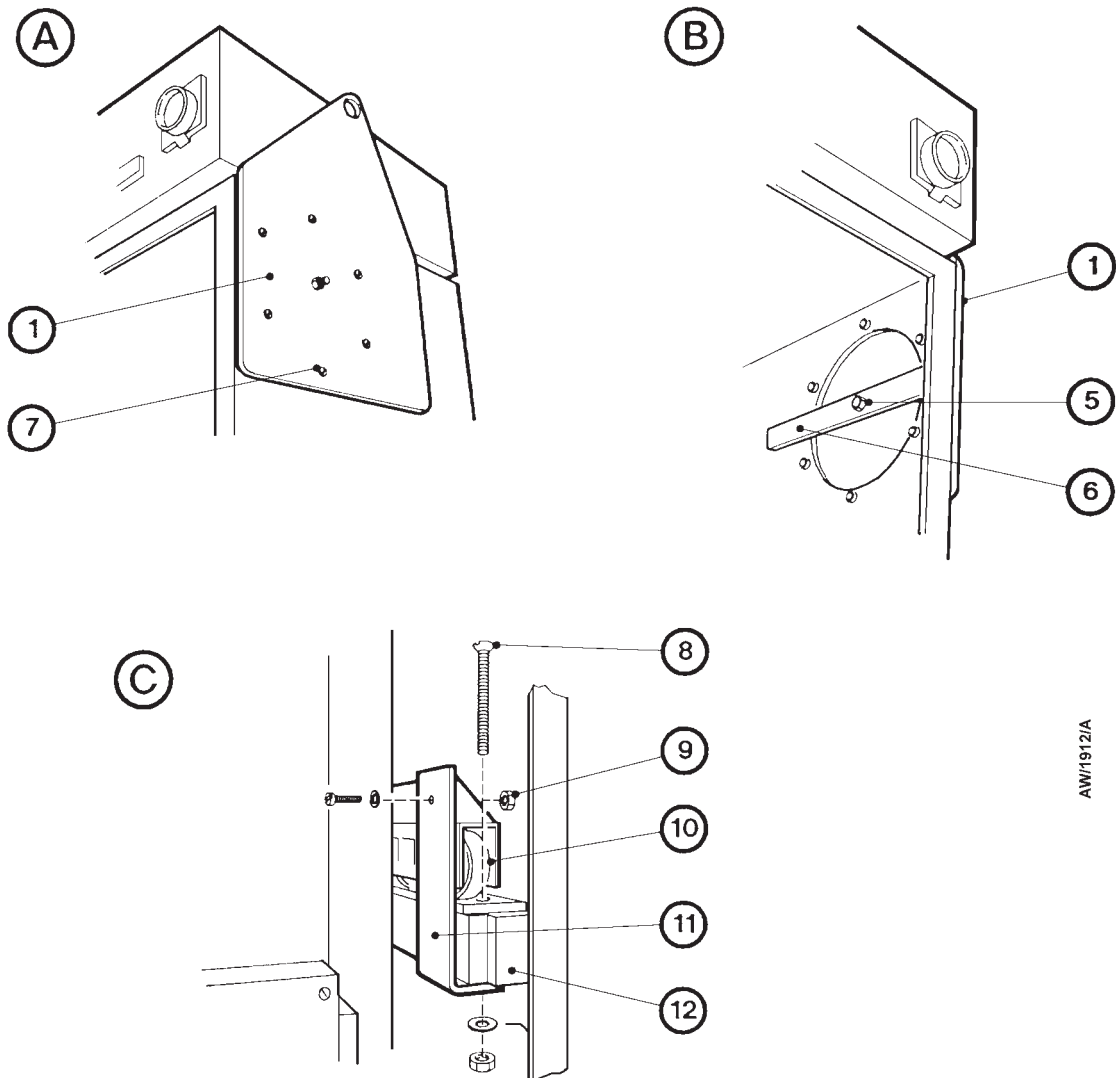

Figure 3-1 - Remove the transit bracket and support: sheet 1 of 2



AW/1912/A

- | | |
|------------------------|--------------------------|
| 1. Lifting bracket | 7. Bolts (6 off) |
| 2. Wooden cross-member | 8. Bolt, nut and washer |
| 3. Transit support | 9. Bolt, nut and washer |
| 4. Bolt (4 off) | 10. Roller carriage |
| 5. Nut | 11. Transit bracket |
| 6. Cross-bar | 12. Heater support frame |

Figure 3-1 - Remove the transit bracket and support: sheet 2 of 2

3.4 Locate the M150 enclosure

WARNING

Use suitable lifting equipment to move the M150. The mass of the M150 with the heater unit fitted is 165 kg.

Before you install the M150, prepare a suitable base for the M150 enclosure. The base must be firm and level and you must leave enough space to enable the heater unit to be easily moved into and out of its operating position: see Figure 2-1. Do not allow debris to get into the M150 or the pipelines when you install the M150.

1. Refer to Figure 3-1. Remove the four screws (4) which secure the M150 enclosure to the mini-pallet.
2. Refit the transit support (3) in the enclosure, under the heater unit.
3. Close the door of the enclosure.
4. Attach suitable lifting equipment to the lifting brackets (1) and move the M150 enclosure into its final operating position. Ensure that there is enough space in front of the enclosure for you to easily remove the heater units (see Figure 3-4).
5. Refer to detail B. Open the door of the enclosure, then undo the nuts (5) and remove the cross-bars (6) from the inside of the enclosure.
6. Refer to detail A. Undo the bolts (7) which secure the lifting brackets (1) to the sides of the enclosure and remove the lifting brackets. Retain the bolts and the lifting brackets for future use.

3.5 Remove the transit bracket and level the enclosure

1. Refer to Figure 3-1. Remove the wooden cross-member (2) and the transit support (3) from the enclosure.
2. Refer to detail C. Remove the nut, bolt and washer (9) which secure the transit bracket (11) to the roller carriage (10) of the heater unit.
3. Remove the nut, bolt and washer (8) which secure the transit bracket (11) to the enclosure side frame (12) and remove the transit bracket.
4. Refit the bolt, washer and nut (8) to the enclosure side frame (12).
5. If necessary, place plates under the enclosure so that the heater unit hangs vertically in the enclosure and so that the gaps between the heater unit and the sides of the enclosure are equal.
6. Use suitable bolts through the four fixing-holes in the base of the enclosure(s) to secure the enclosure in position (see Figure 3-4).

3.6 Connect the remote fault outputs (if required)

WARNING

If the flow of untreated process gas into your exhaust-extraction system may result in a hazardous situation, you must incorporate suitable safety precautions in your control system.

Notes: Table 3-2 shows the default contacts used in the M150 when supplied, for each of the fault conditions. These contacts can be configured; if you want to change the contacts used, contact your supplier or BOC Edwards for advice.

The top panel of the control unit has a 9-pin remote fault connector (Figure 3-2, item 7). Pins in this connector are connected to contacts which are open or closed when a fault conditions is present (that is, a red fault LED is on), as shown in Table 3-2. Contacts on pins 7 and 3, and on pins 7 and 8 are warning contacts. Contacts on pins 1 and 6, and on pins 1 and 2 are alarm contacts.

If required, you can interlock these signals to your process system, central control or to the safety system. A mating socket is supplied with the M150.

Red fault LED on status display	Figure 1-6 key	Open contact pin numbers	Closed contact pin numbers
Compressed gas	16	7 and 3	7 and 8
Heater power	15	1 and 6	1 and 2
Earth leakage trip *	14	1 and 6	1 and 2
Circuit breaker	13	7 and 3	7 and 8
Warning pressure	12	7 and 3	7 and 8
Alarm pressure	11	1 and 6	1 and 2
Lower cartridge temperature	10	1 and 6	1 and 2
Lower heater temperature	9	1 and 6	1 and 2
Flow fault *	6	7 and 3	7 and 8
Phase balance monitor #	5	7 and 3	7 and 8
End point *	4	7 and 3	7 and 8
TMS temperature *	3	7 and 3	7 and 8
Upper cartridge temperature	2	1 and 6	1 and 2
Bypass-valve	1	1 and 6	1 and 2

* Only used if the corresponding accessory or ordering option is fitted to the M150.

Only used on the M150E.

Table 3-2 - Remote fault connector pins

3.7 Connect the gas supplies

Note: Your nitrogen and compressed gas supplies must be clean and dry and must meet the specification in Section 2.

1. Refer to Figure 3-2. Connect your compressed gas supply pipe to the $\frac{1}{4}$ inch Swagelok compressed gas supply connector (9) on the top of the control unit. Do not switch on the compressed gas supply yet.
2. Connect your nitrogen supply pipe to the $\frac{1}{4}$ inch Swagelok nitrogen supply connector (10) on the top of the control unit. Do not switch on the nitrogen supply yet.

3.8 Connect the electrical supply

Use the following procedure to connect the electrical supply to the control unit. Connect the electrical supply through a suitably fused isolator.

1. Refer to Figure 3-2. Undo and remove the four bolts (1) which secure the top panel (2) to the control unit (3), then remove the top panel.
2. Pass your electrical supply cable through the cable gland (11) on the top of the control unit.
3. Refer to detail B. Connect the three phase wires of the electrical supply cable to the phase connections (17) on the electrical supply isolator (19 or 20) inside the control unit.
4. If your electrical supply uses a neutral wire, connect the neutral wire to the neutral connection (18) on the electrical supply isolator (19).
5. Connect the ground (earth) wire of the electrical supply cable to the earth terminal block (13).
6. Tighten the cable gland strain-relief screws.
7. Refit the top panel (2) to the control unit and secure with the four bolts (1). Do not switch on the electrical supply yet.

3.9 Remove the heater unit from the enclosure

1. Refer to Figure 5-1. Ensure that the electrical connectors (2, 3) are disconnected from the heater unit.
2. Switch on the electrical supply to the M150.
3. Carefully remove the heater unit from the enclosure as described in Section 5.4.3, steps 11 to 16.

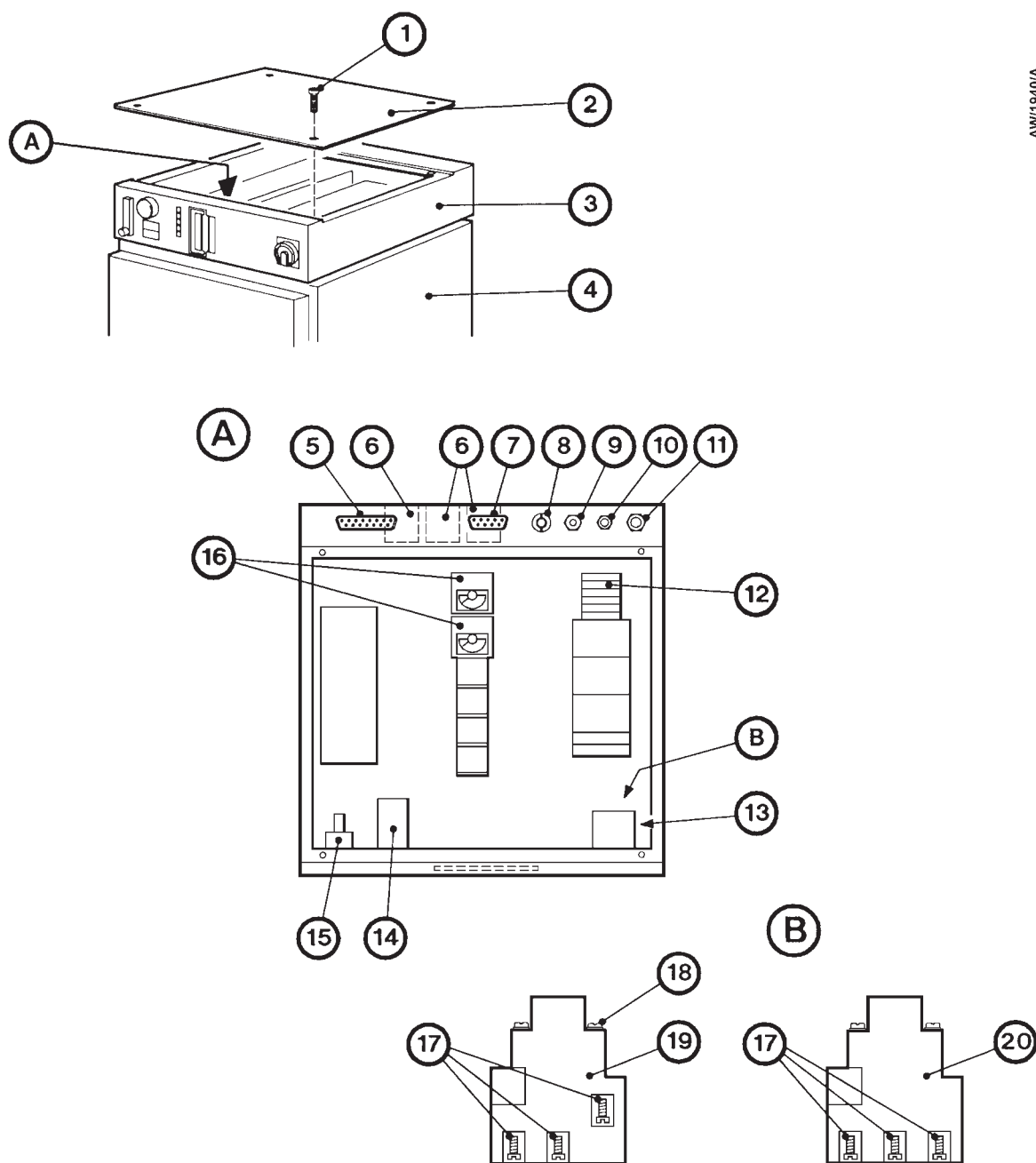

- | | | |
|-----------------------------|---|--|
| 1. Bolt | 10. Nitrogen supply connector | 17. Electrical supply phase connections |
| 2. Top cover | 11. Electrical supply cable-gland | 18. Neutral electrical supply connection |
| 3. Control unit | 12. Fuses | 19. Electrical supply isolator (5-wire electrical supply connection) |
| 4. Enclosure | 13. Earth (ground) terminal (under item 19) | 20. Electrical supply isolator (4-wire electrical supply connection) |
| 5. Remote display connector | 14. Cartridge temperature controllers | |
| 6. Solid-state relays | 15. Nitrogen flowmeter | |
| 7. Remote fault connector | 16. Heater controllers | |
| 8. Remote input connector | | |
| 9. Compressed gas connector | | |

Figure 3-2 - Services connections and interior of the control unit

3.10 Connect the M150 inlet and outlet

Notes: A typical installation configuration is shown in Figure 3-4.

1. Refer to Figure 3-3. Undo and remove the four bolts which secure the inlet seal plates (2, 3) to the rear of the enclosure, and remove the two seal plates.
2. Use an 'O' ring with a metal pressure retaining ring to connect the exhaust pipeline from the pump to the M150 inlet (Figure 1-3, item 5).
3. Refit the seal plates (2, 3) to the rear of the enclosure and secure with the four bolts (1).
4. Connect the M150 outlet (Figure 1-3, item 3) to your exhaust-extraction pipeline: use the method described in Steps 1 to 3 above.

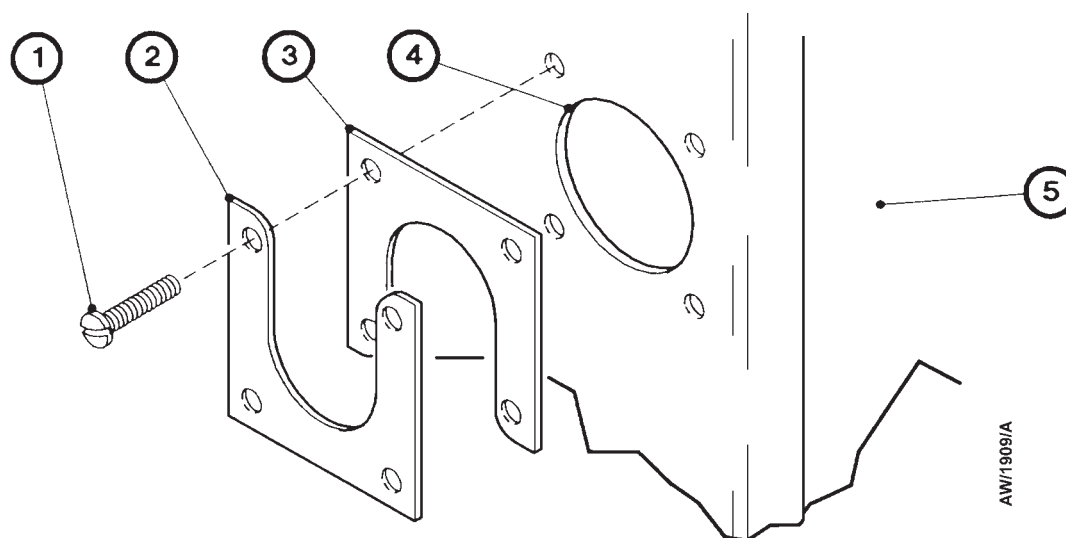

- | | |
|---------------|---------------------|
| 1. Bolt | 4. Leadthrough hole |
| 2. Seal plate | 5. M150 enclosure |
| 3. Seal plate | |

Figure 3-3 - Inlet and outlet seal plates

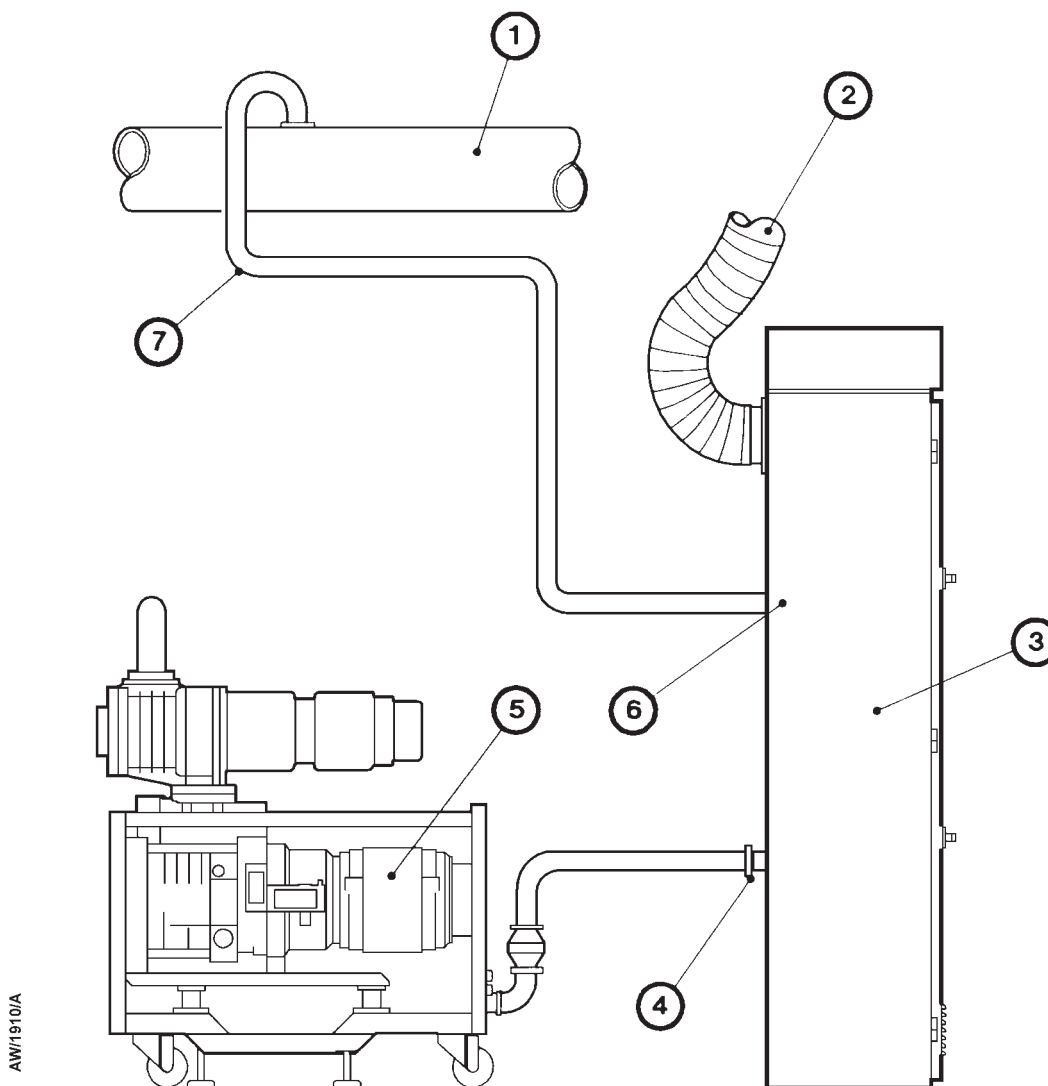

- | | |
|--|---|
| 1. Exhaust-extraction system (metal/plastic) | 5. Pumping system |
| 2. Air-extraction pipe | 6. M150 outlet |
| 3. M150 enclosure | 7. Pipeline from M150 outlet to exhaust-extraction system * |
| 4. M150 inlet | |

* The first two metres of this pipeline must be metal: see Section 3.2.

Figure 3-4 - Typical installation configuration

3.11 Fit a cartridge and refit the heater unit

1. Refer to Figure 5-4, detail A. Pull out the catch (5) on the side of the cartridge change cart, turn the cartridge change cart frame and lock it in the horizontal position as shown in Figure 1-9; when you turn the frame, the safety legs (4) will automatically fall into place.
2. Refer to Figure 5-4, detail C. Remove the heater top-plate (11) from the top of the heater unit.
3. Fit a cartridge to the heater unit (removed in Section 3.9) as described in Section 5.4.5. Note that the inlet elbow and braided flexible bellows are supplied in the fitting-kit.
4. Fit the heater unit (with the new cartridge) in the enclosure as described in Steps 2 to 10 of Section 5.4.6.
5. Refer to Figure 5-1. Tighten the inlet and outlet pipeline clamps (4, 1).

3.12 Connect to your air-extraction system

CAUTION

Ensure that your air-extraction system can provide the necessary air flow (see Section 2). If it does not, the M150 will overheat and shut down.

Refer to Figure 2-2. Note that there are three possible positions for the air-extraction flange (1). Each position has a leadthrough hole.

1. Fit the air-extraction flange to the selected leadthrough hole.
2. Use the bolts removed in Section 3.4 (Figure 3-1, item 7) to fit the two blanking plates supplied to the other two leadthrough holes.
3. Connect the air-extraction flange to your air-extraction system. Your air-extraction system must provide at least the minimum air-extraction specified in Section 2. If it does not, the M150 will overheat and will shut-down or may be damaged.

3.13 Fit the pump exhaust TMS components: optional

CAUTION

If you have a TMS fitted to your M150, you must fit the necessary TMS components to the pipeline between the pumping system and the M150 inlet. If you do not, deposits will form in the M150 process pipelines and the pipelines may become blocked.

If you have the TMS ordering option fitted to your M150, you must fit the necessary TMS components to the pipeline between the pumping system outlet and the M150 inlet. The temperature of the pipeline will then be controlled by the TMS temperature controllers on the control unit.

Use the procedures described in the TMS instruction manuals (supplied as Supplementary Publications) to fit and connect the components.

3.14 Fit additional ordering option components (if necessary)

If you have ordered your M150 with any ordering options, fit any necessary components (supplied with the M150) for the options: refer to Appendices A2 to A9.

3.15 Fit other accessories (optional)

WARNING

Incorporate a safety device to shut down the pumping system if the pipeline between the pumping system and the M150 is over-pressurised.

If you want to use other accessories with your M150, fit them now. Details of the accessories available from BOC Edwards are given in Section 7. Fit and prepare an accessory for use as described in the instruction manual supplied with the accessory.

The M150 cannot respond to pressure surges in the pipelines if the compressed gas supply to the M150 has failed (see Section 1.7). You must therefore incorporate suitable safety devices (such as a gas pressure module) in the system to prevent over-pressurisation of the M150 process pipelines, the pipeline between the pumping system exhaust and the M150 inlet, and the exhaust-extraction system pipeline.

3.16 Leak-test the system

WARNING

Leak test the system after installation and seal any leaks found, to prevent leakage of process gases out of the system and leakage of air into the system.

Before you operate the M150, leak-test the installation and seal any leaks found. Process gases which leak from the system will be dangerous to people and there may be a danger of explosion or fire if air leaks into the system.

If required, you can use the cartridge inlet purge connector (Figure 1-3, item 7) to introduce a search gas into the M150 to assist leak testing.

(This page deliberately left blank)

4 OPERATION

CAUTION

Do not operate the M150 with a gas flow (through the cartridge) less than 5 slm or greater than 60 slm. If the gas flow is not correct, the M150 will not fully treat the process gases.

Note: Refer to Appendices A2 to A9 for additional operation details if you have any ordering options fitted.

4.1 Use of the M150 with new process equipment

When new process equipment is installed and before it has been fully commissioned, it is common practice to use the process equipment to pump large quantities of air. If air is regularly passed through an M150 cartridge, a back-pressure can be created as the moisture in the air will react with the contents of the cartridge. This will reduce the life of the cartridge.

If you use new process equipment in this way, you should therefore leave the M150 switched off and you should close the cartridge inlet and outlet isolation-valves (Figure 1-3, items 8 and 12).

4.2 Start-up

Note: If you want to switch off the alarm beacon while the cartridge warms up, press the alarm cancel button on the control unit (Figure 1-5, item 12).

1. Ensure that only purge gas is flowing through the pumping system, that is, that no process gas is pumped.
2. Ensure the electrical supply isolator (Figure 1-5, item 4) is in the off position.
3. Ensure that the cartridge inlet and outlet isolation-valves (Figure 1-3, items 8 and 12) are both open. The valves are open when the actuating handle is in-line with the pipeline (see Figure 1-3, detail B).
4. Ensure that the sample valve (28) on the cartridge outlet is closed (see Figure 1-3, detail D).
5. Turn on the nitrogen purge supply for the pressure-switch unit; ensure that the supply pressure is between 1.5 and 2 bar gauge (2.5 and 3 bar absolute) and that a flow of approximately 100 slh is shown on the flowmeter on the control unit (Figure 1-5, item 9).
6. Turn on the compressed gas supply; check that the bypass-valve is open. The valve is open when the indicators on the valve actuator disk are in-line with the pipeline (see Figure 1-3, detail C).
7. Switch on the electrical supply and switch on the electrical supply isolator on the control unit (Figure 1-5, item 4).
8. Switch on the heater power switch on the lower control unit (Figure 1-5, item 10).

(Continued on page 4-2)

9. Press the reset button on the lower control panel (Figure 1-5, item 11). The cartridge temperature controllers (Figure 1-5, items 6 and 7) will then go blank for approximately five seconds and then change to show the temperature of the cartridge.

The temperature alarm LEDs on the cartridge temperature controllers (Figure 1-7, item 3) should be on to indicate that the cartridge is outside the operating temperature range and the green heater LEDs (Figure 1-7, item 1) should be on to indicate that the heaters are operating to warm up the cartridge.

10. After approximately 10 to 30 seconds, the bypass-valve will close.
11. Only green LEDs on the status display (Figure 1-6) should then be on, with the exception of the temperature LEDs (Figure 1-6, items 2, 9 and 10); the red temperature LEDs will flash to indicate that the cartridge and the heater are below operating temperature.
12. The M150 will now heat up to its operating temperature which is reached after 60 to 90 minutes. When the temperature of the cartridge is in the operating temperature range, the red temperature alarm LEDs on the temperature controllers will go off.
13. Use the pumping system to pump process gases; the exhaust gases from the pumping system will be treated by the M150 cartridge.

4.3 Cartridge change

When necessary, change the cartridge in the heater unit as described in Section 5.4.

4.4 Fault indications

CAUTION

If the alarm beacon or a red fault LED goes on, take the necessary operator action as soon as possible. If you do not, untreated process gas may flow directly into the exhaust-extraction system.

In normal operating conditions, after the cartridge has heated up to operating temperature, only green LEDs on the status display should be on. If a red fault LED or the alarm beacon goes on, you must immediately determine the cause of the fault and rectify the fault. If you do not, the bypass-valve may open and untreated process gas will flow into the exhaust-extraction system. Refer to Section 5.11 for general fault finding.

If the warning pressure or alarm pressure LEDs are on because you need to change the cartridge, change the cartridge as described in Section 5.4.

4.5 Shut-down

1. Ensure that no process gases are pumped, that is, that only purge gas flows through the pumping system.
2. Use the heater switch on the lower control panel (Figure 1-5, item 10) to switch off the electrical supplies to the heater unit.
3. Switch off the electrical supply isolator on the control unit (Figure 1-5, item 4). Switch off the external electrical supply. The bypass-valve will then open.
4. Close the cartridge inlet and outlet isolation-valves (Figure 1-3, items 8 and 12) to isolate the cartridge from the bypass pipeline.
5. Switch off the nitrogen and compressed gas supplies.

(This page deliberately left blank)

5 MAINTENANCE

5.1 Safety

WARNING

Obey the safety instructions given below and take note of appropriate precautions. If you do not, you can cause injury to people and damage to equipment.

The following general safety precautions apply to all maintenance work:

- A suitably trained and supervised technician must maintain the M150.
- Dismantle the M150 with the correct tools and safety facilities available.
- Ensure that the maintenance technician is familiar with the safety procedures which relate to the products processed by the pumping system. Wear the appropriate safety-clothing when you come into contact with contaminated components. Dismantle and clean contaminated components inside a fume-cupboard.
- Isolate the M150 from the pumping system and allow the M150 to cool to a safe temperature before you start maintenance work.
- Isolate the M150 from the electrical supply so that it cannot be operated accidentally.
- Check that all the required parts are available and of the correct type before you start work.
- Do not reuse damaged 'O' rings.
- Dispose of components safely (see Section 6.2).
- Take care to protect sealing-faces from damage.
- Do not touch or inhale the thermal breakdown products of fluorinated materials which may be present if the seals on the M150 have been heated to 260 °C and above. The seals in the M150 are made from fluorinated materials which are safe in normal use, but can decompose into very dangerous thermal breakdown products if they are heated to 260 °C and above. BOC Edwards Material Safety Data Sheets for fluorinated materials used in the M150 are available on request: contact your supplier or BOC Edwards.
- Leak-test your system after maintenance and seal any leaks found to prevent leakage of dangerous substances out of the system and leakage of air into the system.

5.2 Maintenance plan

The plan shown in Table 5-1 details the maintenance operations necessary to maintain the M150 in normal operation. Further instructions are given in the section shown. If necessary, adjust the maintenance plan according to your experience.

Note that you may need to do other maintenance if your M150 has any ordering options or accessories: refer to Appendices A2 to A9.

Operation	Frequency	Refer to Section
Check the pressure-switch purge and process gas flows	Daily	5.3
Change the cartridge	When necessary	5.4
Check the operation of the pressure-switches	Monthly or on cartridge change	5.5
Check the outlet gas composition (optional)	As required by cartridge change interval	5.6
Replace the thermal fuses	As necessary	5.7
Adjust the cartridge temperature controllers	As necessary	5.8
Adjust the heater controllers	As necessary	5.9
Replace the flexible bellows	Yearly	5.10

Table 5-1 - Maintenance plan

5.3 Check the pressure-switch purge and process gas flows

1. When the M150 is in use and at operating temperature, check that the total process gas flow through the M150 is between 5 and 60 slm.
2. Check that there is a reading of approximately 100 slh on the pressure-switch purge flow-meter on the control unit (Figure 1-5, item 9). If necessary, adjust the flow-control valve (8).

5.4 Change the cartridge

WARNING

You must replace the cartridge when it is exhausted. If you do not, the M150 and your exhaust-extraction system may be damaged by untreated process gases, and untreated process gases may eventually be released into the extracted M150 enclosure, and may cause further equipment damage.

5.4.1 Cartridge life

The life of a cartridge depends on the quantity of process gases treated and a back-pressure will not always be detected before the cartridge has been exhausted. If you do not have an end-point detector in the M150, we recommend that you measure the level of exhaust gases in the outlet pipeline to determine the life of a cartridge on your process.

If your M150 has an end-point detector (see Appendix A2), the end-point detector will determine when a cartridge reaches the end of its life. Alternatively, you can connect a suitable measuring device to the sample port on the outlet pipeline (Figure 1-3, detail D). Suitable devices include:

- Spot samplers

These are tubes of crystals which change colour in the presence of a specific gas. The sampling port is provided with a flexible pipe for connection of spot samplers.

- On-line monitors

Many gas monitors are available; these use either electrochemical cells, chemical-sensitive tape or semiconductor devices. These monitors are generally designed for ambient air monitoring and are very unlikely to be suitable for continuous monitoring of the gases in the M150 outlet, where the gas may be 100% dry nitrogen.

You can connect an on-line monitor to the sampling port to periodically sample the gases. However it may be more suitable to connect the monitor at a point downstream in the exhaust-extraction system, where air and moisture (from other exhaust-extraction pipelines) will be present.

5.4.2 Cartridge change log cards

Cartridge change log cards are supplied with new packs of cartridge. If required, these cards can be used as a reminder to change cartridges at the proper time.

5.4.3 Remove the heater unit from the enclosure

1. Make sure that only purge gas is being pumped, that is, that no process gas is pumped.
2. Use the heater power switch on the lower control panel (Figure 1-5, item 10) to switch off the electrical supplies to the heater unit. The alarm beacon will go on.
3. Switch off the electrical supply isolator (Figure 1-5, item 4). The bypass-valve will automatically open and the alarm beacon will go off.

If you have connected a cartridge inlet-purge nitrogen supply, immediately continue at Step 4, otherwise leave the M150 to cool down for at least 30 minutes, then continue at Step 4.

4. Refer to Figure 5-1. Open the door of the enclosure and close the cartridge inlet isolation-valve (5). If you have a valve locking kit accessory (see Section 7), fit the lock to the valve as described in the instruction manual supplied with the kit.
5. If you have connected a cartridge inlet-purge nitrogen supply, switch on the nitrogen supply; we recommend that you operate the inlet-purge with a flow rate of 30 slm for at least five minutes, then switch off the nitrogen supply.
6. Close the cartridge outlet isolation-valve (6). If you have a valve locking kit accessory (see Section 7), fit the lock to the valve as described in the instruction manual supplied with the kit.
7. Disconnect the electrical connectors (2, 3) from the heater unit.
8. Refer to Figure 5-2. Remove the thermocouple connectors on the cartridge (1) from the thermocouple connectors (2) on the heater unit extension leads.
9. Refer to Figure 5-1. Remove the clamp (1) which secures the cartridge outlet elbow to the M150 pipeline and remove the trapped 'O' ring.
10. Remove the clamp (4) which secures the elbow and braided flexible bellows on the cartridge inlet to the M150 pipeline and remove the trapped 'O' ring.
11. Ensure that the cartridge change cart is in the upright position (see Figure 5-4, detail A).
12. Refer to Figure 5-3. Ensure that the heater unit support arms are in the vertical position (5).
13. Push the cartridge change cart in front of the heater unit, then turn the two support arms (8) so that the pins (9) under the arms go into the holes (11) in the enclosure frame.
14. Press and hold the heater release button (10) and pull the handle (3) on the heater unit to slide the heater unit (2) on its roller bearings (4) onto the cartridge change cart (7).
15. Refer to detail B. Slide the heater unit (2) fully onto the cartridge change cart (7). The catch (6) will then automatically secure the heater unit on the change cart.
16. Lift up the support arms into the vertical position (5) and move the cartridge change cart to the location where you will fit the cartridge.
17. We recommend that you fit blank flanges or blanking caps to the cartridge inlet and outlet flanges in the enclosure.

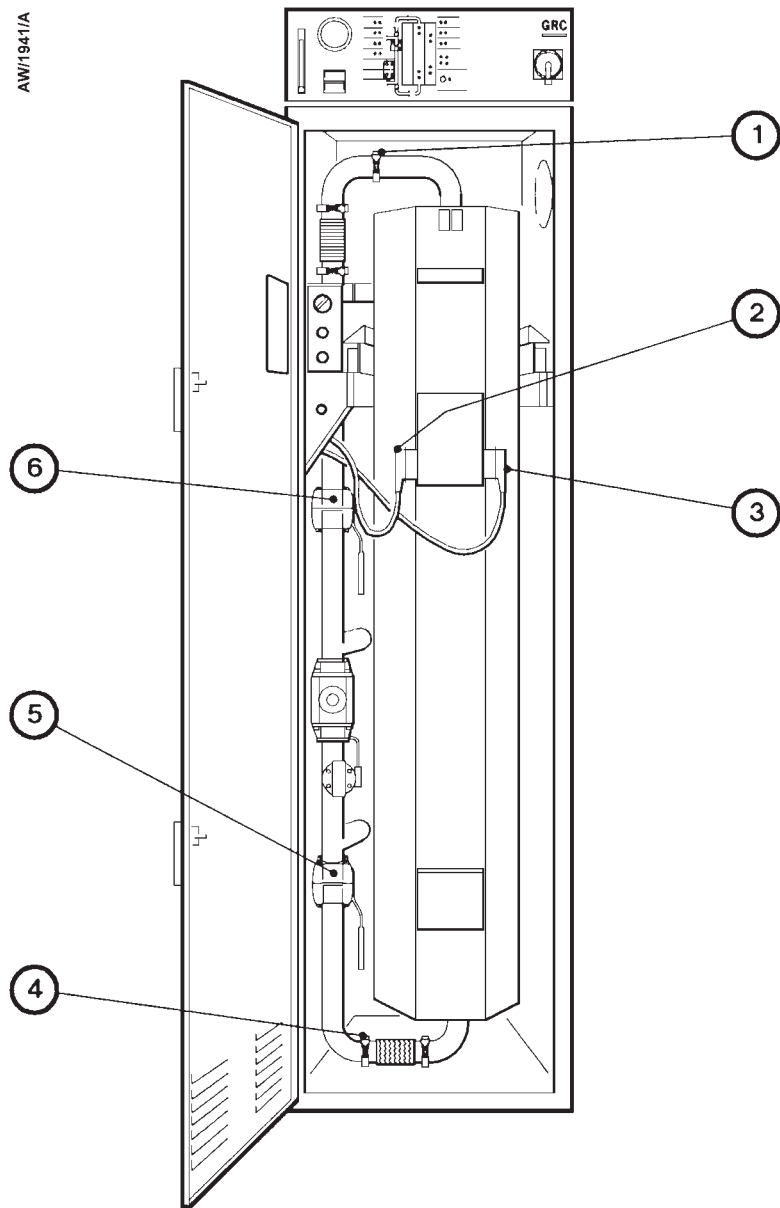

1. Cartridge outlet pipeline clamp
2. Electrical connector
3. Electrical connector
4. Cartridge inlet pipeline clamp
5. Cartridge inlet isolation-valve
6. Cartridge outlet isolation-valve

Figure 5-1 - Disconnect the heater unit from the enclosure

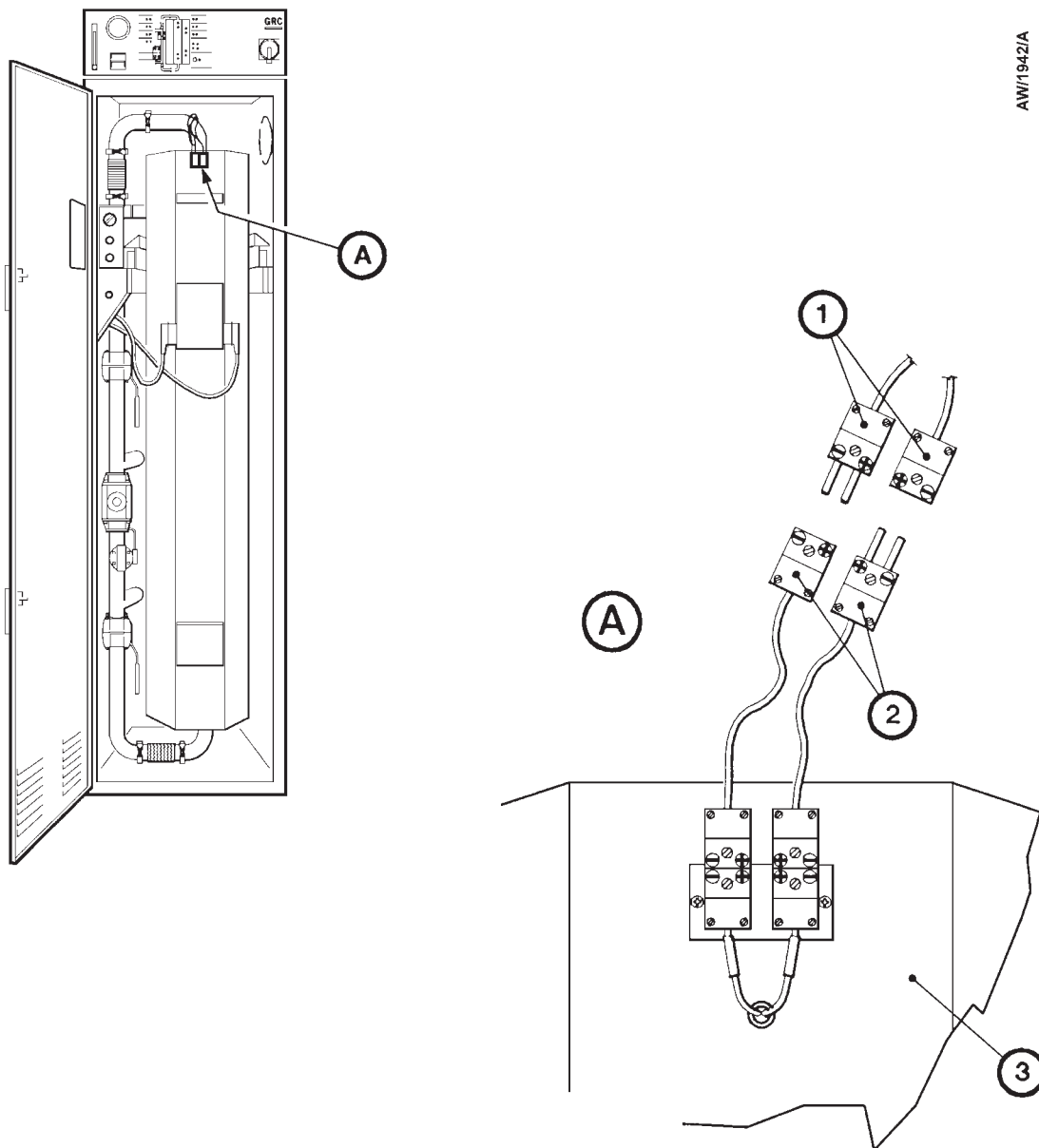

AW/1942/A

1. Thermocouple connectors on cartridge
2. Thermocouple connectors on heater unit extension leads
3. Heater unit

Figure 5-2 - Connect or disconnect the thermocouple connectors

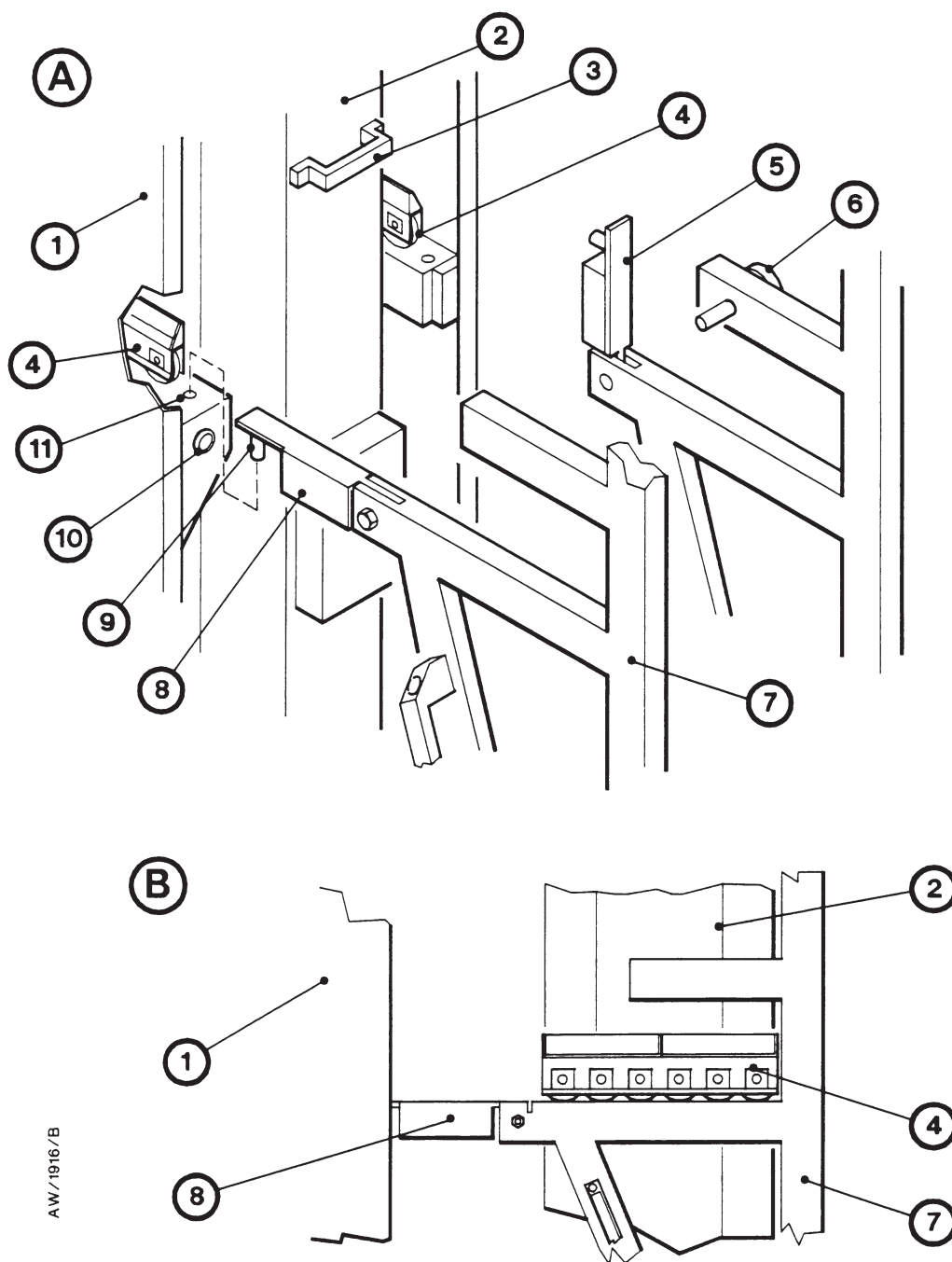

AW/1916/B

- | | |
|--|--|
| 1. Enclosure | 7. Cartridge change cart |
| 2. Heater unit | 8. Heater unit support arm (horizontal position) |
| 3. Handle | 9. Pin |
| 4. Roller carriage | 10. Heater release button |
| 5. Heater unit support arm (vertical position) | 11. Locating hole |
| 6. Catch | |

Figure 5-3 - Remove the heater unit from the enclosure

5.4.4 Remove the used cartridge

WARNING

The mass of an exhausted cartridge is approximately 40 kg. To remove an exhausted cartridge from the heater unit, either use two people (as described in the procedure below), or use suitable mechanical lifting equipment: refer to Appendix A1.

Use the following procedure to replace the used cartridge with a new one. Wear suitable heat-resistant gloves when you remove the cartridge from the heater unit.

1. Refer to Figure 5-4, detail A. Pull out the catch (5) on the side of the cartridge change cart, turn the heater and cart frame and lock it in the horizontal position as shown in Figure 5-4; when you turn the cartridge and heater assembly, the safety legs (4) will automatically fall into place.
2. Refer to detail B. Undo the clamp (7) and remove the elbow (9), braided flexible bellows (10) and trapped 'O' ring (8) from the cartridge inlet (6). Retain the trapped 'O' ring, clamp, elbow and bellows. Refer to detail C. Remove the heater unit top-plate (11).
3. Refer to Figure 5-5. Hold the cartridge outlet elbow (4) and pull the cartridge (6) out of the heater unit by approximately 40 mm.
4. Fit the cartridge change handle (5) over the outlet end of the cartridge.
5. Slowly pull the cartridge (6) from the heater unit (1); as you pull the cartridge out, slide the cartridge change handle (5) down towards the inlet end of the cartridge. One person must use the cartridge change handle and one person must hold the cartridge outlet.
6. Place the used cartridge in a safe place.
7. We recommend that you push the plastic blanking-plugs supplied into the ends of the used cartridge to seal the ends of the cartridge.

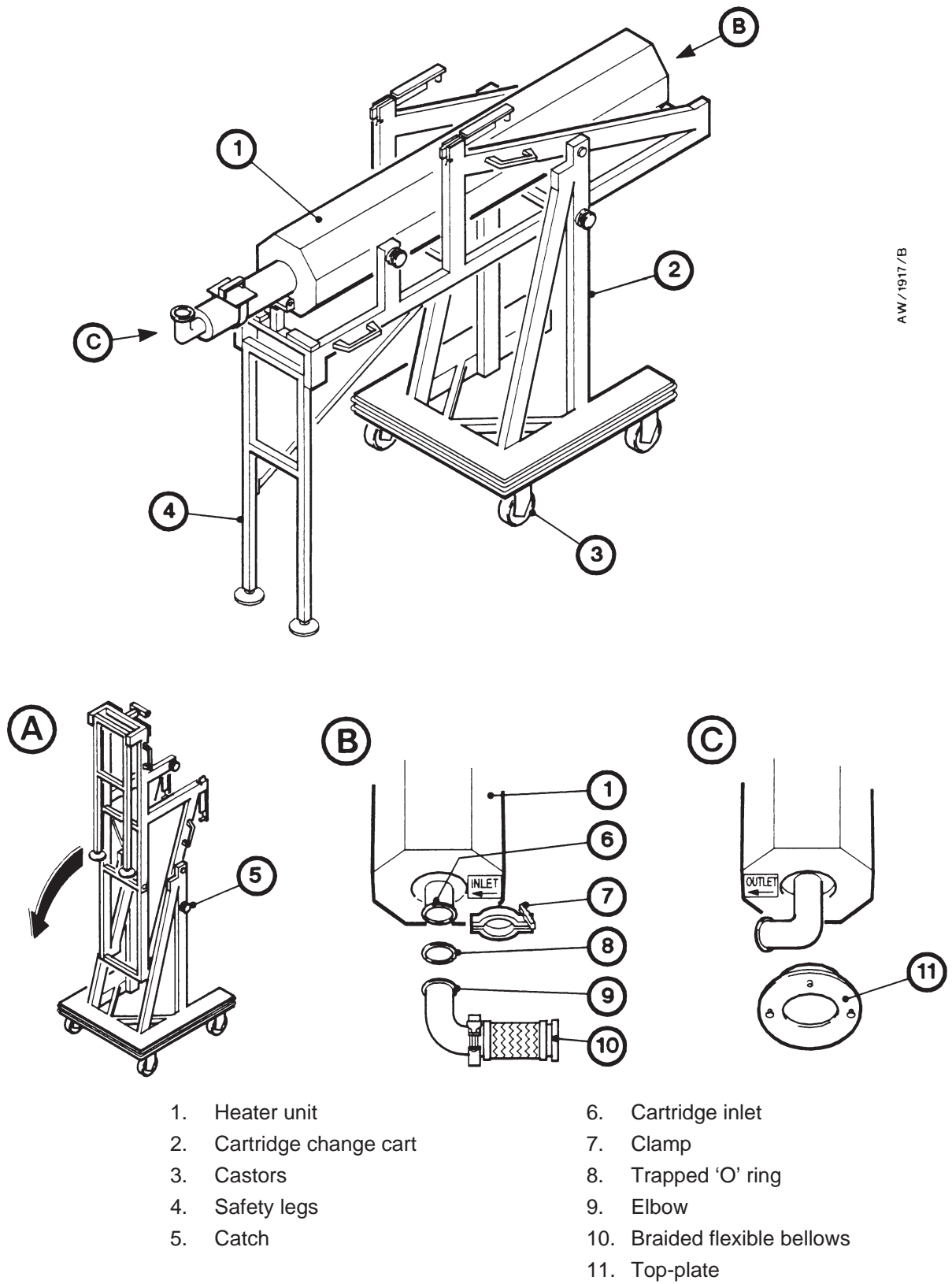
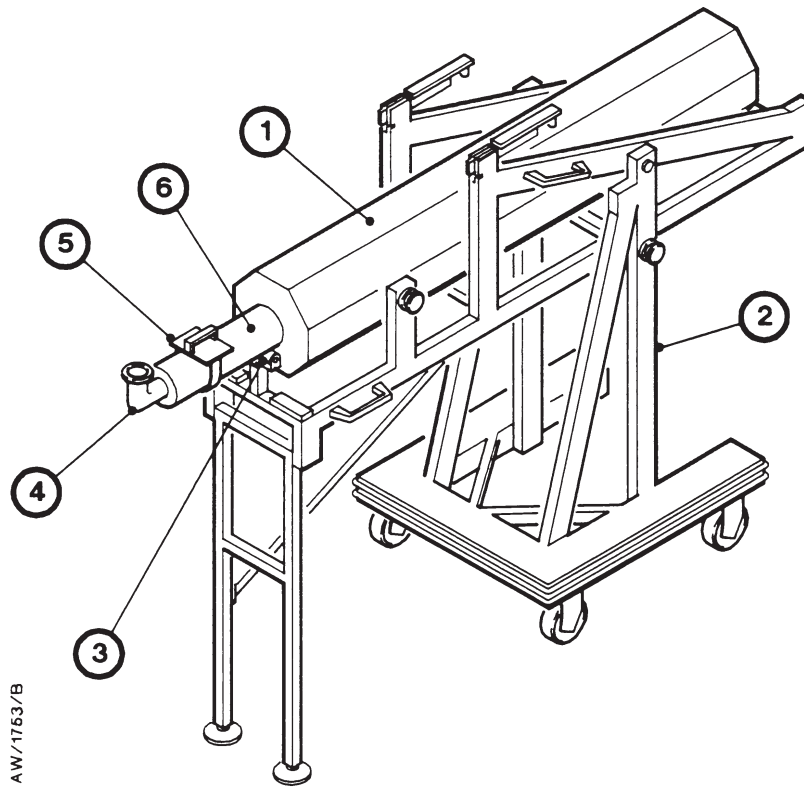

Figure 5-4 - Prepare to remove the cartridge



- | | |
|--------------------------|----------------------------|
| 1. Heater unit | 4. Cartridge outlet elbow |
| 2. Cartridge change cart | 5. Cartridge change handle |
| 3. Roller | 6. Cartridge |

Figure 5-5 - Remove the used cartridge

5.4.5 Fit the new cartridge

WARNING

Ensure that the contents of the new cartridge have not settled. If you use a cartridge whose contents have settled, the efficiency of the M150 will be reduced.

WARNING

The mass of a new cartridge is approximately 39 kg. To fit a new cartridge to the heater unit, either use two people (as described in the procedure below), or use suitable mechanical lifting equipment: refer to Appendix A1.

CAUTION

Take care not to damage the inlet and outlet-flanges of the cartridge when you remove the seals. If you damage the flanges, you may not be able to use the cartridge.

Note: If you think that the contents of the new cartridge have settled (for example, if the cartridge has been stored or transported horizontally), use one of the following methods to resettle the contents:

- *Before you fit the cartridge in the heater unit (in Step 3 below), hold the cartridge vertically, with the outlet elbow at the top, then use a rubber headed mallet to tap all round the outside of the cartridge.*
 - *After you have placed the cartridge in the heater unit and turned the heater unit upright (in Steps 3 and 4 below), but before you fit the top-plate (in Step 5 below), hold the outlet elbow and shake the cartridge from side to side for a minute or more.*
1. Check that the plastic sealing caps are firmly fitted to the cartridge inlet and outlet, and that the caps are undamaged. If the caps are loose or damaged, moisture in the air may have reacted with the contents of the cartridge and reduced its life.
 2. Carefully remove the sealing caps from the cartridge inlet and outlet-flanges; take care not to damage the flange sealing-faces. If the sealing-faces are damaged, process gases may leak from the M150 when you have installed the new cartridge (in the heater unit) in the enclosure.
 3. Refer to Figure 5-5. Slide the new cartridge (6) into the heater unit (1), so that the outlet elbow points upwards, then push the cartridge as far as it will go into the heater unit.
 4. Refer to Figure 5-4, detail A. Pull out the catch (5) on the side of the cartridge change cart and turn the heater and cart frame upright, so that the cartridge falls fully into the heater unit.
 5. Fit the heater unit top-plate (11) to the heater unit.
 6. Pull out the catch (5), turn the cart frame and heater unit and lock it in the horizontal position.

(Continued on page 5-12)

7. Refer to detail C. Turn the outlet elbow of the cartridge anticlockwise to its correct orientation, as shown by the 'outlet' label on the top of the heater unit.
8. Refer to detail B. Use the clamp (7) and trapped 'O' ring (8) to secure the elbow (9) and flexible bellows (10) to the cartridge inlet (6), so that they are in the correct orientation, as shown by the 'inlet' label on the bottom of the heater unit.
9. Refer to detail A. Pull out the catch (5) on the side of the cartridge change cart, turn the heater unit and cart frame and lock it in the upright position.

5.4.6 Refit the heater unit in the enclosure

1. If you have fitted blank flanges or blanking caps to the cartridge inlet and outlet flanges in the enclosure, remove them.
2. Wheel the cartridge change cart in front of the M150 enclosure.
3. Refer to Figure 5-3 detail A. Turn the support arms (5, 8) so that the pins (9) on the arms fit in the locating holes (11) in the enclosure frame.
4. Pull out the catch (6) and push the heater unit (2) on its roller bearings (4) off the cartridge change cart (7), over the support arms (8) and into the enclosure.
5. Pull on the handle (3) to ensure that the catch in the enclosure retains the heater unit. If the heater unit still slides forward, push it fully into the enclosure until the catch engages.
6. Refer to detail A. Turn the support arms into the upright position (5), then remove the cartridge change cart and locate it in its storage position.
7. Refer to Figure 5-1. Ensure that the cartridge outlet elbow is in the correct orientation, then use the clamp (1) and trapped 'O' ring to connect the cartridge outlet elbow to the outlet pipeline in the enclosure.
8. Use the clamp (4) and trapped 'O' ring removed in Section 5.4.3 to connect the flexible bellows on the cartridge inlet elbow to the inlet pipeline in the enclosure.
9. Refer to Figure 5-2. Fit the thermocouple connectors on the cartridge (1) to the thermocouple connectors (2) on the heater unit extension leads. Ensure that the connectors are correctly aligned; that is, that the '+' and '-' indicators on the connectors match.
10. Refer to Figure 5-1. Refit the electrical connectors (2, 3) to the connectors on the heater unit.

5.4.7 Switch on the M150 again

WARNING

Leak test the system after you have fitted a new cartridge and seal any leaks found, to prevent leakage of process gases out of the system and leakage of air into the system.

1. Refer to Figure 5-1. If you have fitted locks on the cartridge inlet and outlet isolation-valves (5, 6), remove the locks. Open the cartridge inlet and outlet isolation-valves.
2. Leak-test the system and seal any leaks found to prevent leakage of process gases out of the system and leakage of air into the system.
3. Close the door of the enclosure.
4. Refer to Figure 1-5. Switch on the electrical supply isolator on the control unit (4). Press the reset button (11) and switch on the heater power switch (10). Temperature will now be displayed on the temperature controllers (6, 7).
5. After approximately 10 to 30 seconds, the bypass-valve will automatically close. After approximately 60 to 90 minutes, the cartridge will reach its operating temperature; you can then start to pump process gases.

5.5 Check the operation of the pressure-switches

You need a pressure gauge kit to check the operation of the pressure-switches. Fit the pressure gauge kit and check the operation of the pressure-switches as described in the instruction manual supplied with the pressure gauge kit.

5.6 Check the composition of the outlet gas (optional)

If you use a monitoring device or a spot sampler to check the composition of the gases at the M150 outlet, we recommend that you regularly check the level of dangerous gases in the outlet to ensure that the level is acceptable.

A regular check of the gases will also enable you to more accurately determine the life of cartridges on your process application.

5.7 Replace the thermal fuses

5.7.1 Replace the enclosure thermal fuse

Refer to Figure 5-6, detail A. The enclosure thermal fuse (3) is located on the terminal block (2) at the top left of the enclosure, next to the leadthrough hole for the cables from the control unit.

To confirm that the fuse has failed, remove the fuse from the terminal block and measure the electrical continuity across the fuse. If there is no continuity, replace the fuse.

5.7.2 Replace the heater unit thermal fuse

Refer to Figure 5-6, detail B. The heater unit has a thermal fuse located under a cover in the top of the heater unit. If you think that the heater unit thermal fuse has failed:

1. Undo the two bolts (4) and remove the cover (5).
2. Remove the fuse from the terminal block and measure the electrical continuity across the fuse:
 - If there is no continuity, the fuse has failed: continue at Step 3.
 - If the fuse has not failed, there may be an electrical fault in the heater unit or the enclosure. Continue at Step 4 to replace the cover, then contact BOC Edwards.
3. Replace or refit the thermal fuse (6) in the ceramic terminal-block, then refit the cover (5) and secure with the two bolts (4).

5.8 Adjust the cartridge temperature controllers

Notes: The procedures in the following sections are only summaries of the complete procedures for adjustment of the temperature controllers. Refer to the temperature controller instruction manual for full information.

5.8.1 Introduction

As supplied, the temperature controllers are preset for correct operation of the M150. You should only change controller settings if you have been advised by your supplier or BOC Edwards of a recommended change of settings (for example, when you intend to use the M150 on a different process application).

For convenience, the procedure to change controller settings is described in the following sections; refer to Figure 1-7 when you use these procedures.

The controller operating parameters are pre-programmed into memory in the cartridge temperature controllers. If you need to re-enter these operating parameters (for example, if they have been accidentally changed), use the procedure described in Section 5.8.6.

5.8.2 Unlock the controller

Before you change controller settings, you must unlock the controller. Use the procedure below.

1. Press and hold ▲ and ▼ for three seconds. The controller display will then show 'TUNE'.
2. Press ▼ to change the display to 'LEVL1'.
3. Press and hold in the * button.
4. Press ▲ twice to change the display to 'LEVL3', then release the * button.
5. Press ▲ 11 times until 'VER' is shown on the display.

(Continued on page 5-16)

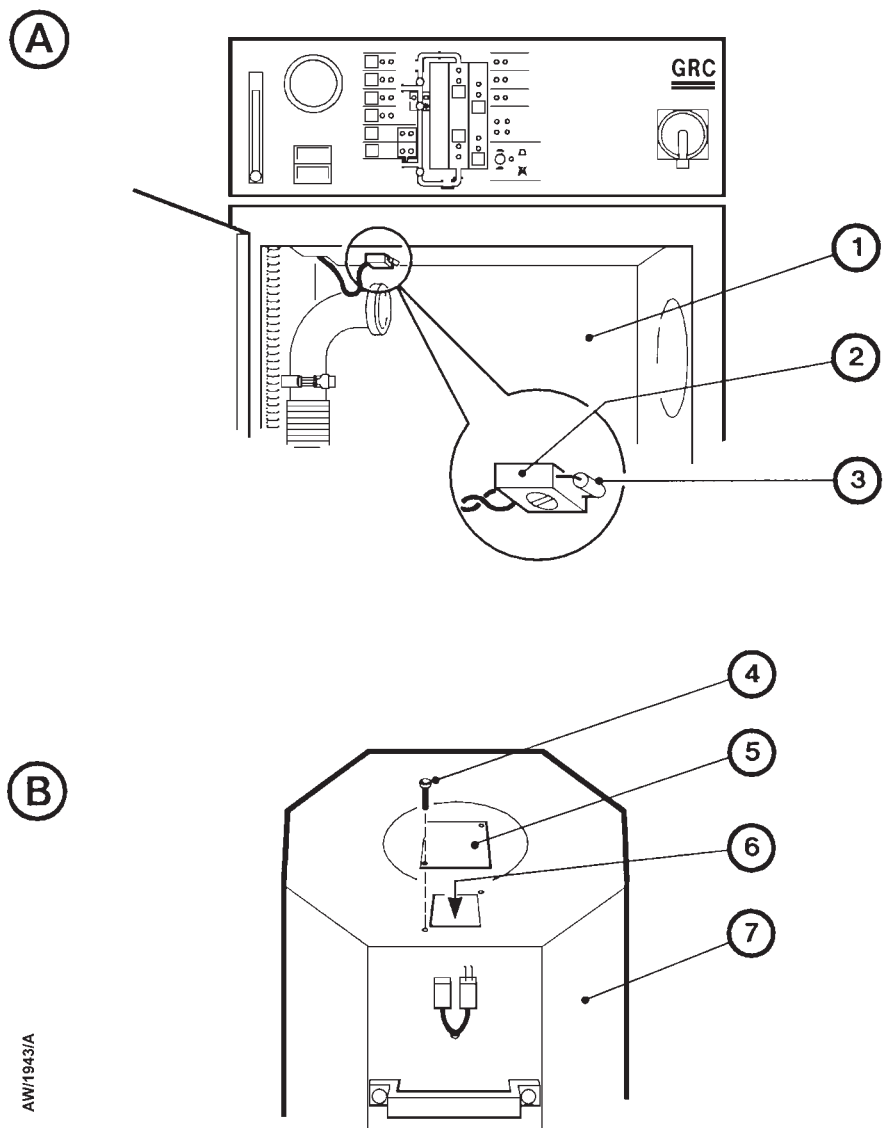

AW1943/A

- A Location of the enclosure thermal fuse
- B Location of the heater unit thermal fuse

- 1. Enclosure
- 2. Terminal-block
- 3. Enclosure thermal fuse
- 4. Bolt
- 5. Cover plate
- 6. Heater unit thermal fuse
- 7. Heater unit

Figure 5-6 - Thermal fuses

6. Press and hold ▲ and ▼ for 10 seconds. When 'LOCK' appears on the display, release ▲ and ▼.
7. Press and hold in the * button.
8. Press ▼ three times until 'NONE' is shown on the display, then release the * button.
9. Press and hold ▲ and ▼ for three seconds to return to temperature display.

5.8.3 Change the default maximum temperature

The controllers are preset to a default maximum temperature. You cannot enter a set point temperature above this maximum temperature into the controller. If you need to change the maximum temperature, use the following procedure:

1. Press and hold ▲ and ▼ for three seconds. The controller display will then show 'TUNE'.
2. Press ▼ to change the display to 'LEVL1'.
3. Press and hold in the * button.
4. Press ▲ and the display will then change to 'LEVL2'. Release the * button.
5. Press ▲ eight times; the display will then show 'HiSc'.
6. Press and hold in the * button.
7. With the * button held in, press ▲ or ▼ to change the display to the required temperature.
8. Release the * button and press and hold ▲ and ▼ for three seconds to return to temperature display.

If you want to change the temperature set point, continue at Section 5.8.4. If you do not wish to change the temperature set point, use the procedure in Section 5.8.5 to lock the new maximum temperature into the controller.

5.8.4 Change the temperature set point

1. Press and hold ▲ and ▼ for three seconds. The controller display will then show 'TUNE'.
2. Press ▲ seven times; the display will then show 'SP.LK'.
3. Press and hold in the * button. Press ▼ to change the display to 'OFF', then release the * button.
4. Press and hold ▲ and ▼ for three seconds to return to temperature display.
5. Press and hold in the * button.
6. With the * button held in, press ▲ or ▼ to change the display to the required set point, then release the * button.
7. Press the * button and confirm that the new temperature is now displayed, then release the * button. If the new temperature is incorrect, repeat Step 6. If the temperature is displayed correctly, continue at Step 8.

8. Repeat Steps 1 and 2; the display will then show 'SP.LK'.
9. Press and hold in the * button. With the * button held in, press ▲ to change the display to 'ON', then release the * button.
10. Press and hold ▲ and ▼ for three seconds to return to temperature display.

5.8.5 Lock the controller

After you have changed controller settings, you must lock the new settings into the controller. Use the following procedure.

1. Press and hold ▲ and ▼ for three seconds. The controller display will then show 'TUNE'.
2. Press ▼ to change the display to 'LEVL1'.
3. Press and hold in the * button.
4. Press ▲ twice to change the display to 'LEVL3', then release the * button.
5. Press ▲ 11 times until 'VER' is shown on the display.
6. Press and hold ▲ and ▼ for 10 seconds. When 'LOCK' appears on the display, release ▲ and ▼.
7. Press and hold in the * button.
8. Press ▲ three times until 'ALL' is shown on the display, then release the * button.
9. Press and hold ▲ and ▼ for three seconds to return to temperature display.

5.8.6 Re-enter the operating parameters into the controller

Each of the temperature controllers has 23 preset functions held in memory; each function has an 'option' which is preset for correct operation of the M150. Use the following procedure to re-enter the options into a temperature controller. You must enter the same options into both controllers.

1. Use the procedure in Section 5.8.2 to unlock the controller.
2. Press and hold ▲ and ▼ for three seconds. The controller display will then show 'TUNE'.
3. Press ▼ to change the display to 'LEVL1'.
4. Use the ▲ and ▼ buttons to select one of the level 1 functions shown in Table 5-2. To set the option for the function:
 - Press and hold in the * button, then press ▲ or ▼ until the required option is displayed.
 - Release the * button.
5. Repeat Step 4 until the correct options have been set for all of the level 1 functions.
6. Press ▼ until 'LEVL1' is shown on the display.

(Continued on page 5-18)

7. Press and hold in the * button. Press ▲ and the display will change to 'LEVL2'. Release the * button.
8. Repeat Steps 4 and 5 until the correct options have been set for all of the level 2 functions.
9. Press ▼ until 'LEVL2' is shown on the display.
10. Press and hold in the * button. Press ▲ and the display will change to 'LEVL3'. Release the * button.
11. Repeat Steps 4 and 5 until the correct options have been set for all of the level 3 functions.
12. Press and hold ▲ and ▼ for three seconds to return to temperature display.
13. Use the procedure in 5.8.5 to lock the options into the controller.
14. Use the procedure in Steps 8 to 10 of Section 5.8.4 to lock the temperature setpoint into the controller.

5.9 Adjust the heater controllers

5.9.1 Introduction

As supplied, the heater controllers are preset for correct operation of the M150 on your process application. Except as indicated in Table 5-3, you should only change controller settings if you have been advised by your supplier or BOC Edwards of a recommended change of settings (for example, when you intend to use the M150 on a different process application).

For convenience, the procedure to change the operating temperature setting on a heater controller is described in Section 5.9.2.

5.9.2 Change the heater temperature setting

Use the procedure below to change the operating temperature setting on a heater controller.

1. Refer to Figure 3-2. Undo the four bolts (1) and remove the top cover (2) of the control unit (3).
2. Refer to Figure 1-8. Use the hexagonal key supplied to turn the controller lock (4) anticlockwise to unlock the controller temperature setting.
3. Turn the temperature adjuster (1) so that the pointer shows the required operating temperature (in oC) on the temperature display (5).
4. Use the hexagonal key to turn the controller lock (4) clockwise to lock the controller temperature setting.
5. Refer to Figure 3-2. Refit the top cover (2) to the control unit (3) and secure with the four bolts (1).

Level	Function	Options	
		Upper temperature controller	Lower temperature controller
1	tunE	oFF	oFF
	bAnd	20	20
	int.t	18	43
	dER.t	200	75
	dAC	4	2.0
	CyC.t	60	60
	oFSt	0	0
	SPLk	oFF *	oFF *
	SEt.2	99	75
	CyC.2	on.oFF	on.oFF
2	SP1.P	100	100
	hAnd	oFF	oFF
	PL.1	100	100
	PL.2	100	100
	SP2.A	bAnd	bAnd
	SP2.b	nonE	nonE
	diSP	1	1
	hiSC	650	650
	LoSc	0	0
	InPt	K	K
	unit	C	C
3	SP1.d	SSd	SSd
	SP2.d	rLy	rLy

* These options will be set to 'on' when the temperature setpoint has been entered into the controller.

Table 5-2 - Cartridge temperature controller operating parameters

5.10 Replace the flexible bellows

Replace the flexible bellows in the cartridge outlet pipeline (Figure 1-3, item 16) and the braided flexible bellows on the cartridge inlet (Figure 5-4, item 10) every year. All connections are NW40.

5.11 Fault finding

5.11.1 General

Note: If you have accessories fitted to the M150 (for example, a TMS or end-point detector), refer also to the fault finding sections of the accessory instruction manuals.

Use Table 5-3 to identify the nature of faults and to determine the actions to be taken to rectify the fault.

If you cannot identify the nature of a fault or you cannot rectify a fault after you have identified it, contact your supplier or BOC Edwards for advice.

Fault	Symptom	Check	Action
F1	All LEDs and lamps are off.	Has the electrical supply failed ? Has a fuse failed ?	Check the external electrical supply and rectify any problem found. Check the transformer and control, circuit breaker and PCB fuses. Only replace a fuse once you have identified and rectified the cause of the failure.
F2	'InPt FAIL' is displayed on a cartridge temperature controller.	Is the thermocouple cable disconnected ? Is the control unit disconnected from the thermocouples on the heater unit ? Is a thermocouple (or controller) faulty ?	Check that the thermocouple connectors on the heater unit are correctly fitted to the cartridge (refer to Section 5.4.6). Check that the control unit thermocouple cable is correctly fitted to the heater unit (see Section 3.11). If all the connectors are correctly fitted, replace the cartridge. If the fault persists, the controller may have failed; contact your supplier or BOC Edwards for advice.
F3	A temperature warning is shown on a cartridge temperature controller: the temperature is too low (and a new cartridge has been fitted and heated for two hours or more).	Is the gas flow through the M150 too high ? Has a heater failed ? Is a thermocouple faulty ?	Ensure that the gas flow is between 5 and 60 slm. Check the current drawn on each phase of the electrical supply (refer to the wiring diagrams in Section 8). Check that the control unit thermocouple cable is correctly fitted to the heater unit (see Section 3.11). If all the connectors are correctly fitted, replace the cartridge. If the fault persists, the controller may have failed; contact your supplier or BOC Edwards for advice.

Table 5-3 - Fault finding

Fault	Symptom	Check	Action
F4	The red compressed gas supply alarm LED is on.	Has the gas supply used to actuate the bypass-valve failed or is the pressure of the gas supply too low ? Is a compressed gas pipe disconnected ?	Check the gas supply. The supply pressure must be as specified in Section 2. Check the pipes; reconnect any disconnected pipe.
F5	A temperature warning is shown on a cartridge temperature controller: the temperature is too high.	Is there a faulty thermocouple in the cartridge ? Is a heater on constantly ? Is there excessive reaction inside the cartridge ? Has a controller failed ?	Check that the control unit thermocouple cable is correctly fitted to the heater unit (see Section 3.11). If the connections are correctly fitted, replace the cartridge. If the fault persists, continue fault finding as described below. Check the currents drawn when the heaters are off. If the current is too high, a solid-state relay may have failed to short circuit and a heater is constantly on. High levels of process gas have reached the M150; check the gas system on your process system for faults. If all of the above checks fail to identify a fault, a controller may have failed: contact your supplier or BOC Edwards for advice. After a high temperature warning, inspect the cartridge outlet 'O' ring and the M150 outlet 'O' ring for damage or thermal set; replace the 'O' rings if necessary.
F6	The red warning pressure LED is on.	Has a back-pressure developed across the cartridge inlet and outlet ?	Check that the back-pressure is due to solid deposits in the cartridge: push the emergency off switch to open the bypass-valve. If the LED goes off, the cartridge is exhausted and must be changed.

Table 5-3 - Fault finding (continued)

Fault	Symptom	Check	Action
F6	The red warning pressure LED is on (continued).	Is the pressure-switch pipeline blocked or is there a blockage in the exhaust- extraction system ?	If the LED does not go off immediately when the bypass-valve opens, the pipeline to the pressure-switches may be blocked or, your exhaust-extraction system may be blocked.
F7	The red warning pressure LED is on and the red alarm pressure LED is on.	Is the plug disconnected from the pressure-switch ? Is the bypass-valve blocked or has it failed ? Is the exhaust-extraction system pipeline blocked ? Is the pressure-switch pipeline blocked or is there a blockage in the exhaust- extraction system ? Is the pressure-switch unit faulty ?	Check that the electrical connectors are correctly fitted to the bypass-valve. If the LEDs remain on when the bypass-valve is open, the valve may be blocked. Shutdown the M150, inspect, clean and refit the bypass-valve and check for correct operation. If the bypass-valve is not blocked, or the LEDs go on again after the valve has been cleaned and refitted, your exhaust-extraction system pipeline may be blocked ; inspect the pipeline and remove any obstructions. Refer to the checks and actions for fault F6. If all of the above actions fail to rectify the fault, the pressure-switch unit may be faulty: contact BOC Edwards for advice.
F8	The red MCB LED is on.	Has the circuit breaker tripped ?	A transient electrical supply failure may have tripped the circuit breaker. Switch off the electrical supply isolator, then switch it on again.

Table 5-3 - Fault finding (continued)

Fault	Symptom	Check	Action
F8	The red MCB LED is on (continued).	Is there an electrical fault (has a phase failed) ? Has a fuse failed ?	Check the connection of the electrical supply to the control unit. If the connections are correct, there may be an electrical fault in the control unit or enclosure: contact your supplier or BOC Edwards. Check the fuses and replace as necessary. Only replace a fuse once you have identified and rectified the cause of the failure.
F9	The red heater power LED is on.	Is the heater power switch in the off position ? Has the contactor (CONT1) tripped ? Has the thermal fuse failed ? Is the heater unit disconnected ?	Move the switch to the on position. A transient electrical supply failure may have tripped the contactor. Press the Reset button on the control unit. Refer to Section 5.7.2 to check the thermal fuse. Check that the electrical supply cable is correctly fitted to the heater unit.
F10	A red cartridge temperature LED is on.	Is the gas flow through the M150 too high ? Has a heater failed ?	Ensure that the gas flow is between 5 and 60 slm. Check the currents drawn by the heaters (refer to Section 5.11.2).
F11	The temperature displayed on a temperature controller is increasing rapidly (and is outside the normal expected range).	Are the thermocouple connectors disconnected ?	Check that the thermocouple connectors on the cartridge are correctly fitted to the connectors on the heater unit.
F12	A negative temperature is displayed on a temperature controller.	Are the thermocouple connectors incorrectly fitted ?	Check that the thermocouple connectors are correctly fitted; that is, that the '+' and '-' indicators on the male and female connectors match.

Table 5-3 - Fault finding (continued)

Fault	Symptom	Check	Action
F13	'InPt nOnE' is displayed on a cartridge temperature controller.	Is the cartridge temperature controller unprogrammed, or have the operating parameters in the temperature controller been corrupted ?	Re-enter the operating parameters into the temperature controllers as described in Section 5.8.6.
F14	Both temperature controllers are blank (off).	Has a fuse failed ?	Check the fuses and replace as necessary. Only replace a fuse once you have identified and rectified the cause of the failure.
F15	The red lower heater temperature LED is on and the red lower cartridge temperature LED is on.	Has a heater failed ?	Check the electrical current drawn by the heaters.
F16	The red lower heater temperature LED is on but the cartridge temperature is okay.	Is a thermocouple faulty ?	Check that the thermocouple connectors on the cartridge are correctly fitted to the connectors on the heater unit. If they are correctly fitted, the thermocouples in the cartridge are probably faulty: replace the cartridge.
F17	The red lower heater temperature LED goes on periodically.	Is the gas flow through the M150 too low ?	With a very low gas flow through the M150, the lower heaters may cool and trip the alarms before the lower zone of the cartridge has cooled sufficiently to switch on the lower heater again. Adjust the heater temperature setting on the heater controllers to operate 50 °C cooler: refer to Section 5.9.2.
F18	The red lower remote fault output LED is on.	Is there a pressure surge ?	When the pressure surge is over, the pressure will fall, the bypass-valve will close and the M150 will continue to treat the process gases. If there is not a pressure surge, refer to the checks and actions for fault F6.

Table 5-3 - Fault finding (continued)

5.11.2 Heater and solid-state relay fault finding

To determine whether a heater has failed or whether a solid-state relay has failed, use the following procedure.

1. Switch off the M150 and isolate it from the electrical supply.
2. Remove the connector (labelled SK1 or SOC1) on the end of the heater electrical supply cable from the connector (labelled PL1) on the heater unit.
3. Refer to Figure 5-2. Use a suitable meter to measure the resistances of the five heaters; refer to Table 5-4:
 - If the measured resistance of a heater is in the nominal resistance range, the heater is fully operational.
 - If the measured resistance is > winding failed resistance, one winding in the heater has failed.
 - If the measured resistance is > heater failed resistance, the heater has failed.

If the resistances of the heaters are correct continue at Step 4 to check the solid-state relays.

4. Refer to Figure 3-2. Undo the four bolts (1) and remove the cover (2) from the control unit (3)
5. Remove the cover over the solid-state relays (6).
6. Use a suitable meter to measure the resistances between pins 34-44, 33-43 and 31-41 of the high-voltage terminals of the solid-state relays.
7. All of the resistances should be > 500 k Ω . If any resistance is < 500 k Ω , this indicates that the solid-state relay has failed: contact your supplier or BOC Edwards for advice.

Heater	Rating		Nominal resistance	Winding failed resistance	Heater failed resistance
	M150E	M150J/K/S			
5	2 kW	2 kW	35 \pm 5 Ω	70 Ω	1 k Ω
4	2 kW	2 kW	35 \pm 5 Ω	70 Ω	1 k Ω
3	2 kW	2 kW	35 \pm 5 Ω	70 Ω	1 k Ω
2	680 W	680 W	70 \pm 5 Ω	140 Ω	1 k Ω
1	2 kW	2 kW	35 \pm 5 Ω	70 Ω	1 k Ω

Table 5-4 - Heater resistances

6 STORAGE AND DISPOSAL

6.1 Storage

Store the M150 as follows:

1. Shut down the M150 as described in Section 4.5.
2. If applicable, ensure that the pumping system has been shut down and disconnect the M150 from the pumping system.
3. Fit blanking-plates to the M150 inlet and outlet. Place protective covers over the services connection points.
4. Store the M150 in clean, dry conditions until required.
5. When required for use, prepare and install the M150 as described in Section 3 of this manual.

6.2 Disposal

6.2.1 General

Dispose of the M150 and any components safely in accordance with all local and national safety and environmental requirements.

Take particular care with the following:

- Fluoroelastomers which have decomposed as the result of being subjected to high temperatures
- Components which have been contaminated with dangerous process substances.

6.2.2 Disposal of used cartridges

WARNING

The contents of used C150JV cartridges contain arsenic and are very dangerous. Wear suitable safety clothing when you handle used C150JV cartridges. Dispose of used C150JV cartridges in accordance with all local and national safety requirements.

Dispose of used cartridges safely in accordance with all local and national safety and environmental requirements.

If the M150 has been used on silicon processes with fluorine, chlorine or bromine etching or silane deposition, the used M150 cartridge will contain stable inert solids. Such used cartridges are classified in the UK and some other countries as 'special waste' and are suitable for disposal at sites which are licenced to handle such waste (in accordance with the "Special Waste Regulations, 1996").

If the M150 (with the arsine air tuyere ordering option) has been used on processes with arsine, the used C150JV cartridges will contain dangerous arsenic compounds: you must dispose of these cartridges safely.

Cartridge disposal requirements are based on sample analysis of a typical used cartridge from your process application. If you have any doubt as to the safety of the contents of your used cartridges, or on the sample testing methodology, please contact your supplier or BOC Edwards for advice. Each BOC Edwards site has people who can advise you on how to dispose of cartridges or recycle the cartridges to the steel industry.

7 SERVICE, SPARES AND ACCESSORIES

7.1 Introduction

BOC Edwards products, spares and accessories are available from BOC Edwards companies in Belgium, Brazil, China, France, Germany, Israel, Italy, Japan, Korea, Singapore, United Kingdom, U.S.A, and a world-wide network of distributors. The majority of these centres employ Service Engineers who have undergone comprehensive BOC Edwards training courses.

Order spare parts and accessories from your nearest BOC Edwards company or distributor. When you order, please state for each part required:

- Model and Item Number of your equipment
- Serial number (if any)
- Item Number and description of part.

7.2 Service

BOC Edwards products are supported by a world-wide network of BOC Edwards Service Centres. Each Service Centre offers a wide range of options including: equipment decontamination; service exchange; repair; rebuild and testing to factory specifications. Equipment which has been serviced, repaired or rebuilt is returned with a full warranty.

Your local Service Centre can also provide BOC Edwards engineers to support on-site maintenance, service or repair of your equipment.

For more information about service options, contact your nearest Service Centre or other BOC Edwards company.

7.3 Spares

7.3.1 Cartridges

Spare	Item Number
C150Y cartridges, pack of 2	A223-04-105
C150Y cartridges, pack of 5	A223-04-106
C150Y cartridges, pack of 25	A223-04-108
C150R cartridge, 1 off	A223-04-160
C150R cartridges, pack of 2	A223-04-161
C150R cartridges, pack of 5	A223-04-162
C150JV cartridge, 1 off	A223-04-188
C150JV cartridges, 5 off	A223-04-189

7.3.2 Recommended M150 spares

We recommend that you maintain a stock of at least the following spares:

Spare	Item Number
M150 essential spares kit	A557-01-100
M150 recommended spares kit	A557-01-101
M150 strategic spares kit	A557-01-102
M150S strategic spares kit	A557-02-102
M150J strategic spares kit	A557-03-102
M150K strategic spares kit	A557-04-102
NW40 clamping ring	C105-16-401
NW40 swing clamp	C105-16-403
NW40 Trapped 'O' ring	C105-16-490
NW40 pressure retaining ring	A550-01-030
Ball-valve seal repair kit	22491-015
1 A fuse, 20 mm (pack of 5)	26612-028
100 mA fuse, 20 mm (pack of 5)	26614-067
2 A fuse, 20 mm (pack of 5)	26614-068
2.5 A fuse, 20 mm (pack of 5)	26614-069
Heater unit thermal fuse (pack of 5)	24867-023
Enclosure thermal fuse (pack of 10)	A551-01-006
135 mm braided flexible coupling	C105-04-294
Contactors, 30 A	24621-032
Auxiliary contactor	24629-015
Upper cartridge temperature controller	A551-01-020
Lower cartridge temperature controller	A551-01-021
TC4810 heater controller	28853-017
100 mm flexible coupling	A550-01-084
Braided flexible bellows, NW40	C105-16-294
Thermocouple connectors (pair)	A550-01-063
Thermocouple extension leads (pair)	A551-01-007

7.3.3 Other spares

Spare	Item Number
Pressure-switch and gauge fitting kit	24863-012
1.25 inch ball-valve	22491-038
Cartridge carrier	A550-01-033
Solid-state relay	24651-005
24 V a.c. relay	24464-001
24 V d.c. relay	24464-002
110 V a.c. relay	24464-003
240 V a.c. relay	24464-004
Pneumatic assembly block	A550-01-034
Solenoid plunger assembly	A550-01-036
Actuator assembly	A551-01-027
Emergency Off switch	24827-017

Spare	Item Number
Roller carriage (pair)	A551-01-005
Heater location plate	A551-01-077
Heater unit top-plate	A551-01-078
Pressure-switch assembly	24863-012
Non-return valve (5 psi)	A551-01-080

7.3.4 End-point detector spares

Spare	Item Number
End-point detector sample pump replacement assembly	A550-01-143
End-point detector bottle	A551-01-015
End-point detector sample pipeline replacement kit	A557-01-105
End-point detector filter	A556-84-425
End-point detector electronics assembly	A551-01-032
Complete end-point detector assembly	A551-01-033

7.4 Accessories

7.4.1 Cartridge change cart

The cartridge change cart (see Figure 1-9) allows you to easily remove the heater unit from the M150 enclosure and to easily change a cartridge in the heater unit (see Section 5.4).

Accessory	Item Number
Cartridge change cart	A551-07-000

7.4.2 Valve locking kit

When the heater unit is removed from the enclosure (for example, to change a cartridge), it is possible for the manual cartridge isolation-valves to be opened. If the process is still operating, this will result in the leakage of dangerous process gases into the atmosphere.

The valve locking kit enables the valves to be locked in the closed position to prevent such a possible leakage.

Accessory	Item Number
Valve locking kit	A550-01-011

7.4.3 Exhaust Gas Sample Kit

Use the Exhaust Gas Sample Kit to provide an additional exhaust gas sample port in the M150 pipelines.

Accessory	Item Number
Exhaust Gas Sample Kit	A550-01-142

7.4.4 Remote Display

The Remote Display allows you to remotely control and monitor the operation of the M150, in a location up to 10 metres from the M150 enclosure. Refer to Appendix A9 for a description of the Remote Display.

Accessory	Item Number
Remote Display	A555-25-430

APPENDIX A1 CARTRIDGE HANDLING: SINGLE PERSON OPERATION

WARNING

The mass of new and used cartridges is approximately 40 kg. To handle cartridges, you must therefore use two people as described in Section 4 of this manual, or you must use suitable mechanical lifting equipment, as described in this Appendix.

Note: Contact your supplier or BOC Edwards if you want to handle cartridges as described in the procedures in this Appendix.

A1.1 Introduction

The procedures in Section 5.4 of this manual describe the use of two people to load new cartridges into a heater unit, and to unload used cartridges from a heater unit. If required, you can use suitable special-purpose lifting equipment, so that a single person can handle cartridges.

Refer to Figure A1-1 which shows a special-purpose lifting trolley with a scissors-type cartridge lifting mechanism; the recommended procedures for single person cartridge handling are described in the following sections; where necessary refer to Section 5.4 of this manual for detailed operation of the cartridge change cart.

A1.2 Fit a new cartridge into a heater unit

Note: If you use a suitable scissors mechanism, you will be able to easily judge the centre of the cartridge. This ensures that the centre of mass of the cartridge is within the scissors mechanism when you engage it, so that the cartridge will not topple when you lift it.

1. With the cartridge lying on the floor, move the lifting trolley so that it is next to the cartridge, with the scissors mechanism at approximately the middle of the length of the cartridge.
2. Lower the scissors mechanism and engage and tighten it around the cartridge.
3. Lift the cartridge off the floor as shown in detail A, then move the lifting trolley and cartridge to the heater unit.
4. With the heater unit in the horizontal position, move the lifting trolley so that the end of the cartridge goes into the heater unit, as shown in detail B. Use the trolley to push the cartridge as far as possible into the heater unit, until the scissors mechanism is close to the end of the heater unit.
5. Support the cartridge elbow, then disengage the scissors mechanism and push the cartridge fully into the heater unit.

A1.3 Remove a used cartridge from a heater unit

1. With the heater unit and cartridge in the horizontal position, move the lifting trolley so that the scissors mechanism is close to the cartridge outlet end of the heater unit.
2. Hold the cartridge outlet elbow and pull the cartridge out of the heater unit sufficiently to enable you to engage the scissors mechanism around the cartridge; engage but do not tighten the scissors mechanism.
3. Slide the cartridge out of the heater unit until the scissors mechanism is approximately at the centre of the length of the cartridge, as shown in detail B, then tighten the scissors mechanism.
4. Use the lifting trolley to fully remove the cartridge from the heater unit.
5. Move the lifting trolley to where you will dispose of the cartridge.

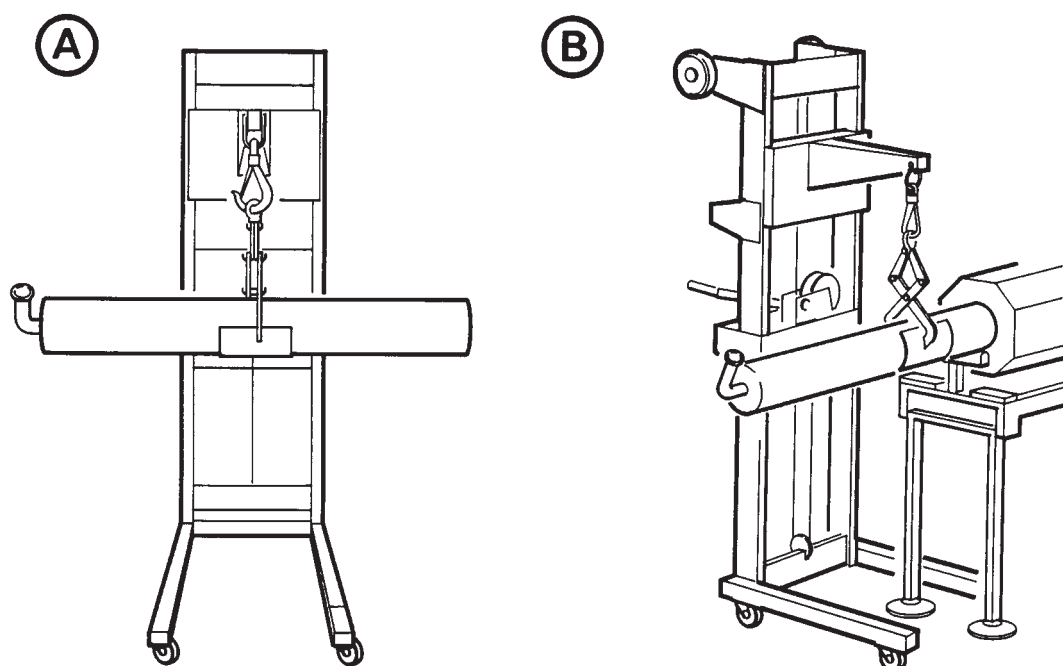

- A Lift the cartridge off the floor/lower the cartridge onto the floor
B Load the cartridge into/unload the cartridge out of the heater unit

Figure A1-1 - Use of special-purpose lifting trolley for single-person cartridge handling

APPENDIX A2 END-POINT DETECTOR ORDERING OPTION

A2.1 Description

A2.1.1 Principle of operation

When the M150 is used on certain applications (see Section A2.1.2), this option provides an indication that the cartridge in the M150 is chemically exhausted.

Refer to Figure A2-1 which shows the end-point detector components in the M150 enclosure. During M150 operation, the sample pump (14) pumps bubbles of gas from the cartridge outlet pipeline through the fluid in the end-point detector bottle (10). The acid gases are dissolved into the fluid and the remaining gases are released into the cabinet at the air-extraction port.

The end-point detector (7) measures the conductivity of the fluid in the end-point detector bottle (10); the change in conductivity depends on the quantity of process gases which pass through the fluid. The end-point detector uses these measurements to determine the cumulative concentration of toxic or corrosive process gas which passes from the outlet of the cartridge, and so determines when the cartridge is chemically exhausted.

A2.1.2 Applications

The end-point detector is sensitive to acid gases such as SiCl_4 , BCl_3 and SiF_4 . You should order the end-point detector option when you expect cartridge exhaustion to result in the release of small concentrations of these gases into your exhaust-extraction system.

The end-point detector option is **not** suitable for use on applications where water-soluble gases pass through the M150 untreated (for example, applications which use NH_3), as this will result in excessively frequent cartridge replacement.

If you have any doubts as to the suitability of the end-point detector with your application, contact your supplier or BOC Edwards for advice.

A2.2 Technical data

Mass of end-point detector components	2 kg
End-point detector type	Acid gas content analyser
Sensitivity	Approximately 100 ppm hours (cumulative)
Fluid	
Type	Deionised or demineralised water
Initial conductivity	0.2 to 5.0 $\mu\text{S}\cdot\text{cm}^{-1}$
Bottle fluid charge	450 ml

A2.3 Additional installation requirements

A2.3.1 Unpack and inspect

When you unpack and inspect the M150 (as described in the M150 instruction manual), check that you have received the additional component shown in Table A2-1. If the component is missing, notify the supplier in writing within three days.

Qty	Description	Check (✓)
1	Container of end-point detector fluid	<input type="checkbox"/>

Table A2-1 - Additional end-point detector components

A2.3.2 Fill and fit the end-point detector bottle

When you install the M150, before you refit the heater unit in the M150 enclosure, fill and fit the end-point detector bottle in the enclosure: use the procedure in Section A2.5.1.

A2.4 Operation

WARNING

You must replace the cartridge when it is exhausted (that is, when the red end point LED is on). If you do not, the M150 and your exhaust-extraction system may be damaged by untreated process gases, and untreated process gases may eventually be released into the extracted M150 enclosure, and may cause further equipment damage.

When the end-point detector option is fitted and the M150 is switched on, the end-point sample pump will regularly sample the gas from the cartridge outlet, and the end-point detector will automatically monitor the sampled gas. With this option fitted, the end point and flow fault LEDs on the M150 status display (see Figure 1-6) are used as follows:

End point The green LED is on when the end-point detector is connected to the M150 control unit and is operating correctly and the cartridge is effectively treating the process gases.

The red LED is on when the end-point detector has identified that the cartridge has reached the end of its useful life. If the red LED goes on, you must change the cartridge in the M150.

Flow fault The green LED is on when gas is being sampled correctly. The red LED is on when gas is not being sampled correctly by the sample pump: refer to Section A2.5.2.

If you do not replace the cartridge when the end-point detector indicates that it is exhausted (that is, the red end point LED is on), the conductivity of the fluid in the end-point detector bottle will continue to rise and the red flow fault LED will go on. This will happen shortly after the red end point LED has gone on.

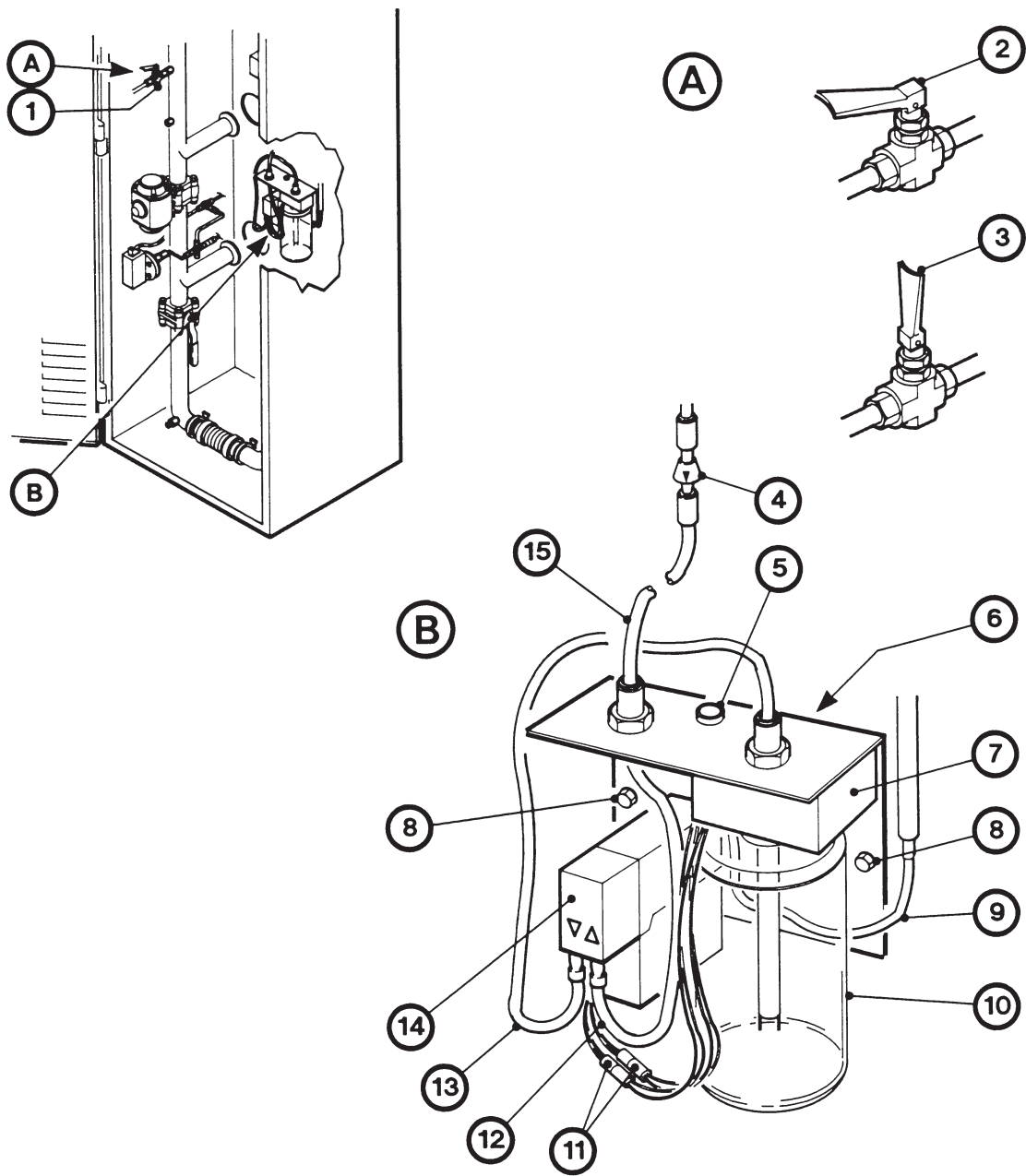

- | | |
|---|-------------------------------|
| 1. End-point inlet isolation-valve | 9. End-point outlet pipe |
| 2. End-point inlet isolation-valve (closed) | 10. End-point detector bottle |
| 3. End-point inlet isolation-valve (open) | 11. Bullet connectors |
| 4. Particulate filter | 12. Sample pump inlet pipe |
| 5. Pump test button | 13. Sample pump outlet pipe |
| 6. Screws | 14. End-point sample pump |
| 7. End-point detector | 15. End-point inlet pipe |
| 8. Nuts | |

Figure A2-1 - End-point detector components

A2.5 Maintenance

A2.5.1 Refill the end-point detector bottle

CAUTION

Refill the end-point detector bottle with fluid of the correct conductivity. If you do not, spurious flow faults will occur.

Note: The conductivity of the deionised water supply in a semiconductor manufacturing facility is typically $0.06 \mu\text{S}\cdot\text{cm}^{-1}$ (equivalent to a resistivity of $18 \text{M}\Omega\cdot\text{cm}$).

After you have removed a used cartridge and before you fit a new cartridge, you must refill the end-point detector bottle. When you refill the end-point detector bottle, you must ensure that the fluid in the bottle is in the correct conductivity range, as specified in Section A2.2.

If you have a supply of deionised water with a conductivity less than $0.2 \mu\text{S}\cdot\text{cm}^{-1}$, you can refill the end-point detector bottle with this water as long as you have adjusted the water's conductivity into the correct range. Use one of the following methods:

- Leave the open bottle to stand in air for 30 to 60 minutes. In this time, the water will dissolve sufficient carbon dioxide from the air to bring the conductivity of the water into the correct range.
- Dissolve 0.5 cm^3 of pH indicator solution in 450 cm^3 of the deionised water. pH indicator solutions are weak acids, and the addition of a small amount of such a solution results in an increase in the water's conductivity, but not sufficiently to shorten the time taken to indicate breakthrough.

We recommend that you use the second method given above, as pH indicator solutions change colour to provide a visual confirmation of the change in acidity of the fluid in the end-point detector bottle.

If you use a pH indicator solution in the end-point detector fluid, the fluid may or may not change colour before the cartridge has reached the end of its life; this will depend on the indicator you use. For example, the pH indicator in the fluid supplied changes from blue to orange-pink at a pH value of 4.5. This is the same pH value at which the end-point detector indicates that the cartridge has reached the end of its life. However, if you use an indicator (for example Bromophenol Blue) which changes colour when its acidity is 3.5, the end-point detector will indicate that the cartridge has reached the end of its life before the fluid changes colour.

Refer to Figure A2-1 and use the following procedure to fill the end-point detector bottle.

1. Move the end-point inlet isolation-valve to the closed position (2).
2. Unscrew and remove the end-point detector bottle (10) from the end-point detector (7).
3. Safely dispose of the contents of the bottle; note that the contents will be mildly acidic.

4. Rinse the bottle three times with clean water, then fill the bottle with the correct charge of new fluid (as shown by the level indicator on the bottle).
5. Firmly screw the bottle (10) back onto the end-point detector (7).
6. Move the end-point isolation-valve to the open position (3).

A2.5.2 Replace the end-point sample pump

You must replace the end-point sample pump after every 4500 hours (six months) of operation. Use the following procedure to replace the end-point sample pump:

1. Switch off the M150 and isolate it from the electrical supply.
2. Remove the heater unit from the enclosure: refer to Section 5.4.3.
3. Refer to Figure A2-1. Disconnect the end-point inlet and outlet pipes (15, 9) from the end-point detector assembly.
4. Undo and remove the two nuts (8), then remove the end-point detector assembly from the rear of the M150 enclosure.
5. Disconnect the sample pump inlet and outlet pipes (12, 13) from the end-point sample pump (14).
6. Disconnect the two bullet connector halves (11) on the sample pump wires from the bullet connector halves (11) on the wires fitted to the end-point detector (7).
7. Undo and remove the two screws (6) from the rear of the end-point detector assembly and remove the end-point sample pump (14) from the assembly. Dispose of the end-point sample pump: refer to Section 6.2.
8. Fit the new end-point sample pump (14) to the end-point detector assembly and secure in place with the two screws (6).
9. Connect the bullet connector half (11) on the end of the red sample pump wire to the bullet connector half (11) on the red wire fitted to the end-point detector (7).
10. Connect the bullet connector half (11) on the end of the black sample pump wire to the bullet connector half (11) on the black wire fitted to the end-point detector (7).
11. Connect the sample pump inlet and outlet pipes (12, 13) to the inlet and outlet on the end-point sample pump (14).
12. Refit the end-point detector assembly into the enclosure (so that the studs on the rear of the enclosure pass through the fixing holes on the assembly), then fit and tighten the two nuts to secure the assembly in place.
13. Connect the end-point inlet and outlet pipes (15, 9) to the end-point detector assembly.

A2.5.3 Fault finding

Symptom	Check	Action
The end-point red LED is on.	<p>Has the cartridge reached the end of its life ?</p> <p>Is the end-point detector disconnected or is it faulty ?</p> <p>Is the conductivity of the fluid in the end-point detector bottle in the correct range ?</p> <p>Is the end-point detector faulty ?</p>	<p>Change the cartridge.</p> <p>Check that the end-point detector is correctly connected to the control unit.</p> <p>If you have just replaced the cartridge, ensure that you have also replaced the fluid in the end-point detector bottle with new fluid of the correct conductivity: refer to Section A2.5.1.</p> <p>If the end-point detector is correctly connected, you have replaced the fluid in the the end-point detector bottle with new fluid of the correct conductivity and you have just changed the cartridge (that is, end-point is almost immediately shown for a new cartridge), the end-point detector may be faulty: contact your supplier or BOC Edwards.</p>
The flow fault red LED is on.	<p>Is the level of fluid in the end-point detector bottle too low ?</p> <p>Are the isolation-valves closed ?</p> <p>Is the end-point detector bottle incorrectly fitted ?</p> <p>Is one of the end-point detector pipelines blocked ?</p> <p>Is the end-point detector disconnected from the control unit ?</p> <p>Is the conductivity of the fluid in the end-point detector bottle too low ?</p>	<p>Check the level of fluid in the bottle and refill if necessary: refer to Section A2.5.1.</p> <p>Ensure that the end-point inlet and outlet isolation-valves are open.</p> <p>Check that the 'O' ring in the cap is in place and that the end-point detector bottle is correctly fitted to the end-point detector.</p> <p>Check the pipelines and unblock if necessary.</p> <p>Check that the end-point detector is correctly connected to the control unit.</p> <p>Check that the conductivity of the fluid you use is in the correct range: refer to Sections A2.2 and A2.5.1.</p>

Table A2-2 - End-point detector fault finding

Symptom	Check	Action
The end-point red LED and the flow fault red LED are both on.	<p>Has the cartridge reached the end of its life ?</p> <p>Is the conductivity of the fluid in the end-point detector bottle in the correct range ?</p>	<p>Change the cartridge.</p> <p>If you have just replaced the cartridge, ensure that you have also replaced the fluid in the end-point detector bottle with new fluid of the correct conductivity: refer to Section 6.5.1.</p>

Table A2-2 - End-point detector fault finding (continued)

(This page deliberately left blank)

APPENDIX A3 TMS (TEMPERATURE MANAGEMENT SYSTEM) ORDERING OPTION

A3.1 Description

A3.1.1 Principle of operation

The TMS components heat the M150 process inlet pipelines to reduce the deposition of solids in the pipelines. Note that if you have ordered this option, you must also fit TMS components to the pipeline between the pumping system outlet and the M150 inlet: refer to Section A3.3.2.

A3.1.2 Installation details

Refer to Figure A3-1. The TMS heaters, thermocouples and insulation jackets fitted in the M150 enclosure are as described below.

- Pipe heaters (4, 5, 7 and 8) are fitted to the M150 inlet pipelines.
- A thermocouple (6) is fitted under the pipe heater on the M150 inlet.
- Insulation jackets (10, 11, 13 and 14) are fitted to the inlet pipeline, to the bypass-valve (9) and to the cartridge inlet isolation-valve (12).

A TMS distribution unit (1) is fitted in the M150 enclosure. This distribution unit is connected to the TMS temperature controller (see below) and to the thermocouple, and provides the electrical supplies for the pipe heaters fitted to the inlet pipeline.

A TMS temperature controller is fitted to the M150 control panel (see Figure 1-5). This temperature controller monitors the thermocouple and switches the pipe heaters on and off to maintain the inlet pipeline at the required temperature:

Additional fuses FS/FB4 to FS/FB6 and FS/FB8 are located in the M150 control unit: see Figure 3-2); the fuse ratings are given in Section A3.2.

A3.2 Technical data

Mass of TMS components fitted to enclosure 7 kg

Fuse ratings	M150E	M150S/J/K
FS/FB4	4 A	4 A
FS/FB5	0.25 A	0.25 A
FS/FB6	10 A	10 A
FS/FB8	-	4 A

A3.3 Additional installation requirements

A3.3.1 Unpack and inspect

When you unpack and inspect the M150 (as described in the M150 instruction manual), check that you have received the additional components shown in Table A3-1. If any component is missing, notify your supplier in writing within three days.

Qty	Description	Check (✓)
2	FS5/FS6 fuses (4 A)	<input type="checkbox"/>
2	FS7 fuses (250 mA or 50 mA)	<input type="checkbox"/>
2	FS8 fuses (10 A or 4 A)	<input type="checkbox"/>
1	TMS instruction manual	<input type="checkbox"/>

Table A3-1 - Additional TMS components

A3.3.2 Fit the pump exhaust TMS components

WARNING

If your M150 has the TMS installation option, you must fit the necessary TMS components to the pipeline between the pumping system outlet and the M150 inlet. If you do not, this will result in the deposition of solids in the M150 process pipelines and the pipelines may become blocked.

You must fit a TMS distribution unit and the necessary TMS components (not supplied with the M150) to the pump exhaust pipeline (that is, the pipeline between the pumping system outlet and the M150 inlet). The temperature of the pipeline will then be controlled by the TMS Controller. Note that the M150 can control a maximum length of 3 m of pipe heaters fitted to the pump exhaust pipeline.

Refer to the TMS instruction manual for the procedures to fit the TMS components.

A3.4 Operation

Once switched on, the TMS components will automatically heat the M150 inlet pipeline and the pipeline between the pumping system outlet and the M150 inlet.

Operation of the TMS temperature controller on the M150 control unit is identical to the operation of the M150 cartridge temperature controllers: refer to Section 1.3.

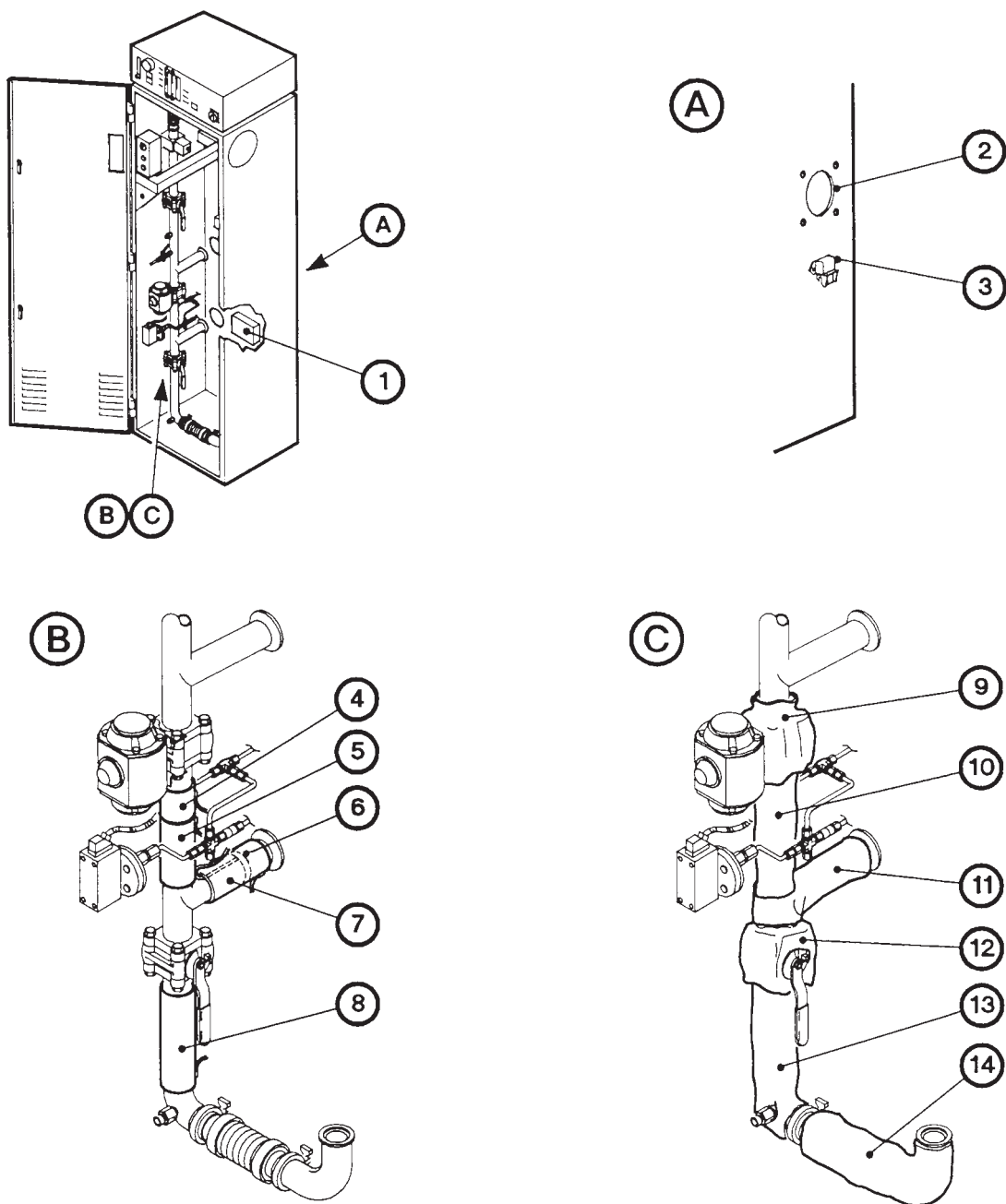

AW/4575/A

- | | | |
|-----------------------------|-----------------------------------|---------------------------------------|
| 1. Distribution unit | 6. Thermocouple (under item 5) | 11. Pipeline insulation jacket |
| 2. M150 inlet leadthrough | 7. Pipeline heater | 12. Isolation-valve insulation jacket |
| 3. TMS electrical connector | 8. Pipeline heater | 13. Pipeline insulation jacket |
| 4. Pipeline heater | 9. Bypass-valve insulation jacket | 14. Pipeline insulation jacket |
| 5. Pipeline heater | 10. Pipeline insulation jacket | |

Figure A3-1 - TMS components

A3.5 Maintenance

A3.5.1 Re-enter the operating parameters into the TMS temperature controller

To re-enter the operating parameters into the TMS temperature controller, use the same procedures as for the M150 cartridge temperature controllers (refer to the M150 instruction manual). The TMS temperature controller operating parameters are shown in Table A3-2.

Level	Function	Option
1	tunE	oFF
	bAnd	1
	int.t	3
	dER.t	7
	dAC	1
	CyC.t	20
	oFSt	0
	SPLk	oFF *
	SEt.2	20
	CyC.2	on.oFF
2	SP!.P	0
	hAnd	oFF
	PL.1	100
	PL.2	100
	SP2.A	bAnd
	SP2.b	nonE
	diSP	1
	hiSC	120
	LoSC	0
	InPt	K
	unit	C
3	SP1.d	SSd
	SP2.d	rLy

* These options will be set to 'on' when the temperature setpoint has been entered into the controller.

Table A3-2 - TMS temperature controller operating parameters

A3.5.2 Fault finding

Symptom	Check	Action
A temperature warning is shown on the TMS temperature controller: the temperature is too low.	<p>Is a TMS fitted to the pump exhaust pipeline ?</p> <p>Is the gas flow through the M150 too high ?</p> <p>Are the heaters and insulation jackets correctly fitted ?</p> <p>Has a heater thermal fuse failed ?</p> <p>Is the thermocouple faulty ?</p> <p>Is there another fault ?</p>	<p>Fit a TMS to the pump exhaust pipeline as described in the TMS instruction manual.</p> <p>Ensure that the gas flow is between 5 and 60 slm.</p> <p>Check that the heaters and insulation jackets are correctly fitted.</p> <p>Check the heaters as described in the TMS instruction manual. Replace heaters if necessary.</p> <p>Check that the thermocouple is correctly connected to the distribution unit. If the connections are correct, the thermocouple may be faulty: check and replace as necessary.</p> <p>If the fault persists, the controller, control unit or distribution unit may have failed: contact your supplier or BOC Edwards for advice.</p>
A temperature warning is shown on the TMS temperature controller: the temperature is too high.	<p>Is the thermocouple faulty ?</p> <p>Has the controller failed ?</p>	<p>Check that the thermocouple is correctly connected to the distribution unit. If the connections are correct, replace the thermocouple.</p> <p>If the fault persists, continue fault finding as described below.</p> <p>If all of the above fail to identify a fault, the controller may have failed: contact your supplier or BOC Edwards for advice.</p>
'InPt FAIL' is displayed on the TMS temperature controller.	<p>Is the thermocouple disconnected from the distribution unit ?</p>	<p>Check that the thermocouple is correctly fitted to the distribution unit. If the connections are correct, the thermocouple or cable may be faulty: check and replace as necessary.</p>

Table A3-3 - TMS fault finding

Symptom	Check	Action
'InPt nOnE' is displayed on the temperature controller.	Is the controller unprogrammed or have the operating parameters been corrupted ?	Re-enter the operating parameters into the TMS temperature controller as described in Section 5.8.6.
The TMS temperature controller is blank (off).	Has fuse FS5 or FS6 failed ?	Check the fuses and replace as necessary. Only replace the fuses if you have identified and rectified the cause of the failure.
The TMS temperature controller shows a permanent temperature alarm (the pipeline heaters are below the correct temperature).	Has fuse FS8 failed ? Has a pipe heater thermal fuse failed ?	Check the fuse and replace as necessary. Only replace the fuse if you have identified and rectified the cause of the failure. Inspect the pipe heaters. If the thermal fuse on any pipe heater has failed, replace the pipe heater. Ensure that you determine the cause of the failure and rectify it before you operate the M150 again.

Table A3-3 - TMS fault finding (continued)

APPENDIX A4 LEAK TEST ORDERING OPTION

A4.1 Description

This option allows you to automatically leak test the cartridge and M150 pipelines after you have fitted a new cartridge to the M150.

Refer to Figure A4-1 which shows the leak test components in the M150 enclosure. When you open the nitrogen isolation-valve (16) and press the start button (2) to start an automatic leak test:

- The solenoid valve (12) opens to admit nitrogen into the cartridge inlet pipeline and to pressurise the cartridge and the cartridge inlet and outlet pipelines.
- The solenoid-valve is then closed.
- The pressure transducer (10) then monitors the pressure fall in the inlet pipeline to determine if it is leak tight.

The leak test control box (8) has a button and LEDs which are used as follows:

Start button (2)	Press this to start the automatic leak test: refer to Section 5.3.
Power LED (3)	This LED is on to indicate that the electrical supply to the control box is on (that is, the external electrical supply is on and the M150 electrical supply isolator is on).
Pass LED (4)	This LED goes on to indicate that the automatic leak test has completed successfully.
Leak LED (5)	This LED goes on to indicate that the automatic leak test has failed due to a leak.
Blockage LED (6)	This LED goes on to indicate that the automatic leak test has failed due to a blockage.
Testing LED (7)	This LED flashes when the automatic leak test is in progress.

A4.2 Technical data

Mass of leak test components	1 kg
------------------------------	------

A4.3 Operation

CAUTION

Use the procedures in the following sections to start up the M150 and to restart the M150 after you have changed the cartridge. If you do not, and a cartridge has been incorrectly fitted, process gas which leaks from the cartridge pipelines may damage the M150.

A4.3.1 Start-up

Use the following procedure to start-up the M150. This procedure replaces the procedure in the M150 instruction manual. Where necessary, refer to Section 1 for the locations of the M150 controls and components in the enclosure.

1. Ensure that only purge gas is flowing through the pumping system, that is, no process gas is pumped.
2. Turn on the compressed gas supply; check that the bypass-valve is open.
3. Turn on the nitrogen supply; ensure that the supply pressure is between 1.5 and 2 bar gauge (2.5 and 3 bar absolute) and that a flow of approximately 100 slh is shown on the flowmeter on the M150 control unit.
4. Switch on your external electrical supply.
5. Ensure that the sample valve on the cartridge outlet is closed and that the cartridge inlet and outlet isolation-valves are closed.
6. Switch on the electrical supply isolator on the M150 control unit.
7. Refer to Figure A4-1. Move the nitrogen isolation-valve to the open position (16).
8. Refer to detail A. Press the start button (2) on the leak test control box.
9. Wait for the testing LED (7) to go off, indicating that the leak test has been completed, then look at the pass, blockage and leak LEDs on the control box:
 - If the pass LED (4) goes on, the leak test has been completed successfully: continue at Step 10 to start up the M150.
 - If the leak LED (5) or the blockage LED (6) goes on, refer to Section A4.4 to determine the cause of the fault and to rectify the fault.
10. Move the nitrogen isolation-valve to the closed position (15).
11. Open the cartridge inlet and outlet isolation-valves.
12. Switch on the heater power switch on the M150 lower control unit.

(Continued on page A4-4)

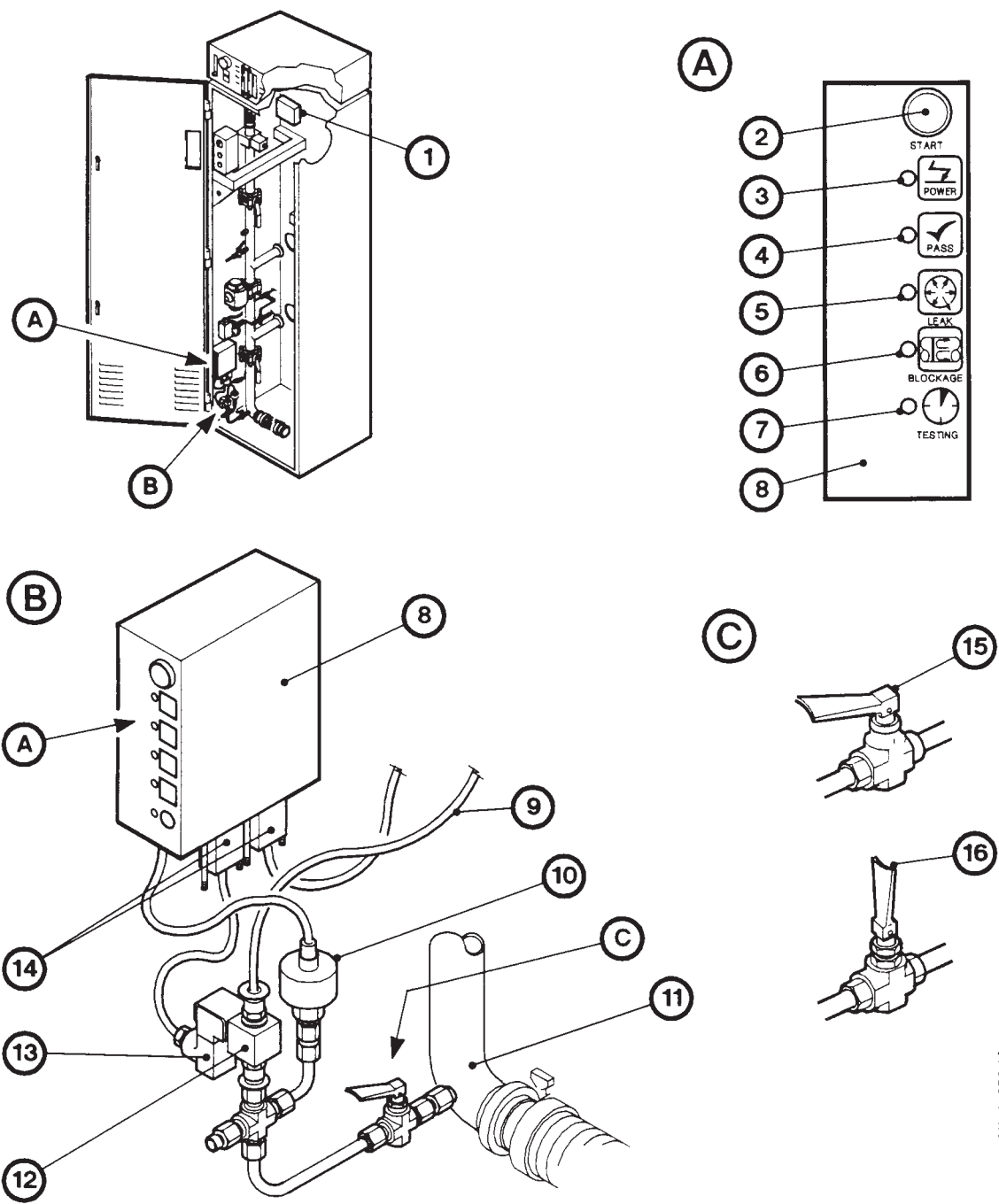

- | | | |
|---------------------|--------------------------|---------------------------------------|
| 1. Distribution box | 6. Blockage LED | 11. cartridge inlet pipeline |
| 2. Start button | 7. Testing LED | 12. Nitrogen solenoid-valve |
| 3. Power LED | 8. Leak test control box | 13. Valve connector |
| 4. Pass LED | 9. Nitrogen pipe | 14. Electrical connectors |
| 5. Leak LED | 10. Pressure transducer | 15. Nitrogen isolation-valve (closed) |
| | | 16. Nitrogen isolation-valve (open) |

Figure A4-1 - Leak test components

13. Press the reset button on the lower control panel. The cartridge temperature controllers will then go blank for approximately five seconds and then change to show the temperature of the cartridge.

The temperature alarm LEDs on the cartridge temperature controllers should be on to indicate that the cartridge is outside the operating temperature range and the green heater LEDs should be on to indicate that the heaters are operating to warm up the cartridge.

14. After approximately 10 to 30 seconds, the bypass-valve will close.
15. Only green LEDs on the status display should be on, with the exception of the temperature LEDs; the red temperature LEDs will flash to indicate that the cartridge and heaters are below operating temperature.
16. The M150 will now heat up to its operating temperature which is reached after approximately 60 to 90 minutes. When the temperature of the cartridge is in the operating temperature range, the red temperature alarm LEDs on the temperature controllers will go off.
17. Use the pumping system to pump process gases; the exhaust gases from the pumping system will be treated by the M150 cartridge.

A4.3.2 Restart after cartridge change

After you have changed the cartridge in the M150, use Steps 5 to 17 of the procedure in Section A4.3.1 to leak test a newly fitted cartridge and to continue to use the M150 to treat process gas.

A4.4 Maintenance

A4.4.1 Regular maintenance

The leak test ordering option requires no additional regular maintenance.

A4.4.2 Fault finding

Symptom	Check	Action
The power LED on the leak test control box does not go on when the M150 electrical supply isolator is switched on.	Has the electrical supply failed ?	Check that the external electrical supply is switched on.
	Is the leak test control box disconnected ?	Ensure that the leak test control box is connected to the distribution box in the enclosure.
The leak LED goes on.	Is the cartridge mis-fitted ?	Undo the cartridge inlet and outlet connections and refit them correctly, then try the leak test again.
	Is there a leak in the cartridge ?	If you have reconnected the cartridge inlet and outlet connections, there may be a leak in the cartridge. Fit a new cartridge and try the leak test again.
	Are the cartridge inlet and outlet isolation-valves open ?	Close the valves, then try the leak test again.
The leak LED goes on (continued).	Is the nitrogen pressure too low ?	Check that the pressure of your nitrogen supply is as specified in the M150 manual. Rectify any problem found, then try the leak test again
The blockage LED goes on.	Is the nitrogen pressure too high ?	Ensure that the nitrogen pressure is as specified in the M150 instruction manual.
	Is the nitrogen isolation-valve closed ?	Ensure that the nitrogen isolation-valve is open and try the leak test again.
	Is there a blockage in the inlet or outlet pipelines ?	Disconnect the cartridge inlet and outlet connections and inspect the inlet and outlet pipelines for blockage or deposits. Rectify any problem found, refit the connections and try the leak test again.
	Is there a blockage in the cartridge ?	Remove the cartridge, fit a new cartridge and try the leak test again.
The blockage LED goes on and the pass LED goes on approximately 70 seconds later.	Is the nitrogen isolation-valve closed ?	Ensure that the nitrogen isolation-valve is open and try the leak test again.

Table A4-1 - Leak test fault finding

(This page deliberately left blank)

APPENDIX A5 AIR TUYERE (FOR ARSINE AND AIR INJECTION APPLICATIONS) ORDERING OPTIONS

A5.1 Description

A5.1.1 Introduction

The air tuyere installation option introduces dry compressed air into the cartridge, where the air reacts with certain process by-products and converts them into stable solid salts. Two types of air tuyere option are available:

- The arsine air tuyere option, designed for use with process applications which use arsine: you must use C150JV cartridges with this option.
- The standard air tuyere option, for other process applications which require the introduction of air into the cartridge: you must use C150R cartridges with this option.

Before you use the M150 with the air tuyere option, ensure that it is suitable for use on your process application. You must **not** use the M150 with the air tuyere option on metal etch/polysilicon etch applications. BOC Edwards Application Data Sheet P12-1 (available on request) provides application information for the M150.

A5.1.2 Installation details

Refer to Figure A5-1 which shows the air tuyere components in the M150 enclosure.

The compressed air supply is taken through a T-piece from the M150 compressed air supply pipeline, and passes through the flow-control valve (2) and the flow-meter (1). The air supply is then routed through the quick-release connectors (5, 6), through the flexible and rigid air tuyere pipes (7 and 10) and into the tuyere pipe in the cartridge (9).

Both C150R and C150JV cartridges have an integral stainless steel air tuyere pipe, as shown in detail B.

The C150JV cartridge used with this option is shown in detail C. A C150JV cartridge (23) has a red identification tab (22) and captive blanking caps on the cartridge outlet (24) and the cartridge inlet; these enable you to blank off the inlet and outlet of a used cartridge when you remove it from the M150. The inlet of a C150JV cartridge is an NW25 flange; this prevents the accidental fitting of a standard C150Y or C150R cartridge in an M150 fitted with the arsine air tuyere option (the inlets of these cartridge types are NW40 flanges).

A5.2 Technical data

Nominal air flow into cartridge	3 slm
Masses	
Air tuyere installation option	2 kg
C150R or C150JV cartridge (unused)	40 kg
M150 enclosure with C150R or C150JV cartridge	207 kg

A5.3 Additional installation requirements

A5.3.1 Unpack and inspect

When you unpack and inspect the M150 (as described in the M150 instruction manual), check that you have received the additional components shown in Table A5-1. If any component is missing, notify the supplier in writing within three days.

Qty	Description	Check (✓)
1	Air tuyere pipe, which consists of:	<input type="checkbox"/>
1	Flexible air tuyere pipe *	<input type="checkbox"/>
1	Rigid air tuyere pipe *	<input type="checkbox"/>

* The pipes are connected when supplied.

Table A5-1 - Additional air tuyere components

A5.3.2 Connect the compressed air supply

CAUTION

You must connect a compressed air supply to the M150; the compressed air must be dry. If you connect a nitrogen supply, the air tuyere system will not operate correctly.

On the standard M150 (without the air tuyere option), the compressed gas supply is only used to pneumatically actuate the bypass-valve. When you connect your compressed gas supply to the standard M150, you can therefore use either compressed air or nitrogen.

If your M150 has the air tuyere option, the compressed air supply for the cartridge is taken from the pneumatic compressed gas supply pipelines in the M150. Therefore, if you have the air tuyere option fitted to your M150, you must connect a compressed air supply to the M150. If you connect a nitrogen supply, the air tuyere system will not operate correctly and the process gases will not be fully treated.

A5.3.3 Connect the air tuyere pipeline to the cartridge

When you have fitted a cartridge in a heater unit and you have refitted the heater unit in the M150 enclosure, you must connect the air tuyere pipes to the cartridge as described in Section A5.6.3.

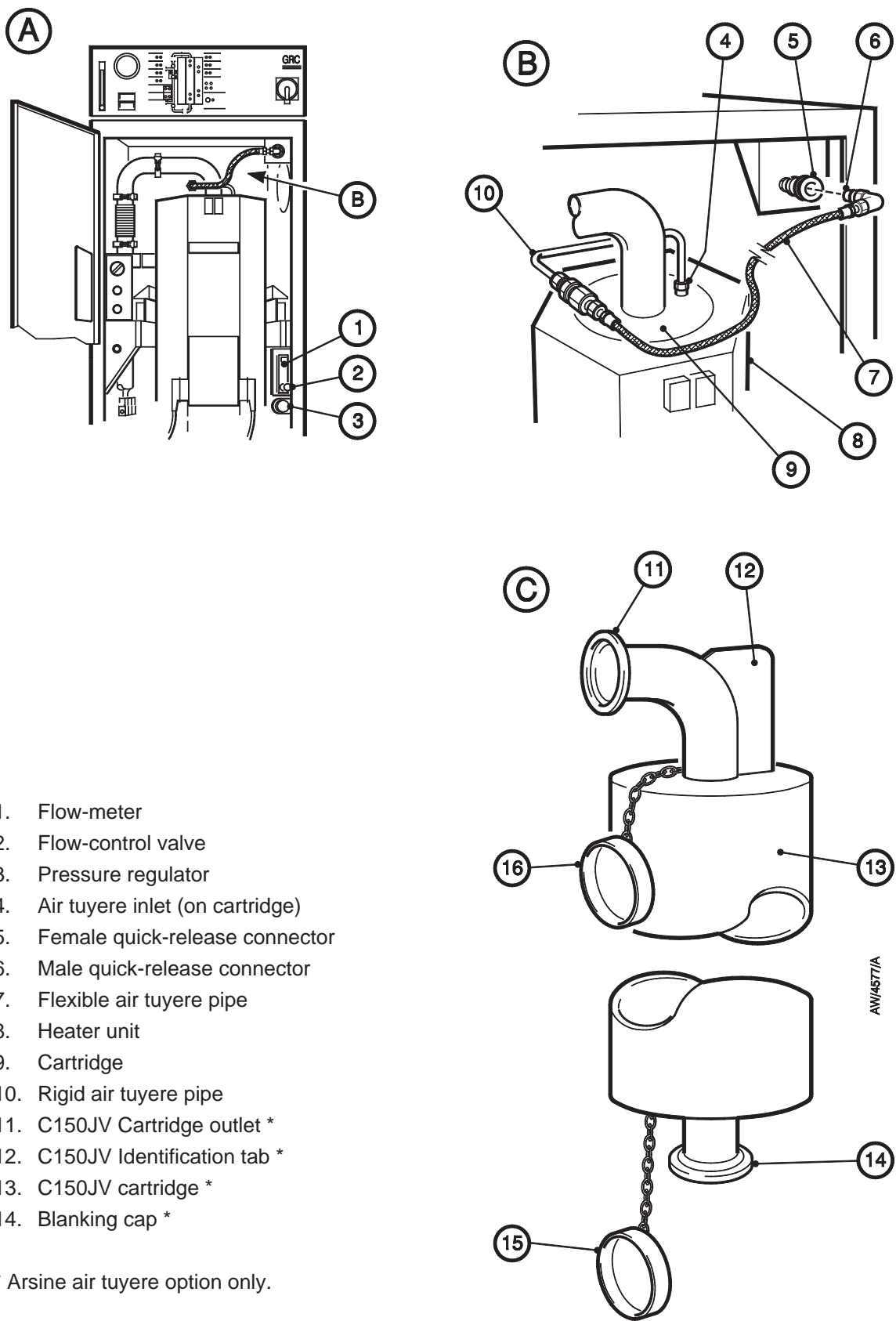

- 1. Flow-meter
- 2. Flow-control valve
- 3. Pressure regulator
- 4. Air tuyere inlet (on cartridge)
- 5. Female quick-release connector
- 6. Male quick-release connector
- 7. Flexible air tuyere pipe
- 8. Heater unit
- 9. Cartridge
- 10. Rigid air tuyere pipe
- 11. C150JV Cartridge outlet *
- 12. C150JV Identification tab *
- 13. C150JV cartridge *
- 14. Blanking cap *

* Arsine air tuyere option only.

Figure A5-1 - Air tuyere components in the M150 enclosure

A5.3.4 Adjust the compressed air flow

After you have switched on the M150 and the bypass-valve has opened, use the following procedure to check the compressed air flow.

1. Open the door of the M150 enclosure.
2. Refer to Figure 5-1. Check that the compressed air flow shown on the air tuyere flow-meter (1) is approximately 5 slm. If necessary, turn the flow-control valve (2) until the correct flow is shown on the flow-meter.

A5.4 Operation

CAUTION

Contact your supplier or BOC Edwards before you use the M150 with the air tuyere option on a process other than that for which it was supplied. If you use the M150 with the air tuyere option on a process for which it is not suitable, the M150 may not treat the process gases correctly.

Compressed air is automatically introduced into the cartridge. The flow-meter (Figure 5-1, item 1) will show the flow of compressed air into the cartridge.

A5.5 Maintenance

A5.5.1 Check the compressed air flow rate

Regularly check the compressed air flow rate into the cartridge and adjust it if necessary: use the procedure in Section A5.3.5.

A5.5.2 Change a cartridge (standard air tuyere option)

Change a cartridge as described in Section 5.4, but with the following additional operations (refer to Figure A5-1):

- After Step 6 of Section 5.4.3: disconnect the quick-release connector (6) on the elbow on the flexible air tuyere pipe (7) from the quick-release connector on the enclosure (5).
- After Step 2 of Section 5.4.4: use a suitable spanner or wrench to disconnect the rigid air tuyere pipe (10) from the air tuyere inlet on the cartridge (4).
- After Step 8 of Section 5.4.5: reconnect the rigid air tuyere pipe (10) to the air tuyere inlet on the cartridge (4).
- After Step 10 of Section 5.4.6: fit the quick-release connector (6) on the end of the flexible air-tuyere pipe (7) to the quick-release connector (5) on the enclosure.

A5.5.3 Change the cartridge (arsine air tuyere option)

WARNING

Use the blanking caps to seal the ends of a used C150JV cartridge; do not inhale fumes from the cartridge. Used C150JV cartridges contain arsenic, which is very dangerous.

Use the procedure in Section 5.4 to change a cartridge, with the following changes (refer to Figure A5-1):

- After Step 6 of Section 5.4.3: disconnect the quick-release connector (6) on the elbow on the flexible air tuyere pipe (7) from the quick-release connector on the enclosure (5).
- In Step 9 of Section 5.4.3, immediately fit the blanking cap (24) to the cartridge outlet (21) after you have disconnected the cartridge outlet from the M150 process pipeline.
- In Step 10 of Section 5.4.3, do not disconnect the clamp which secures the flexible bellows; instead, disconnect the cartridge inlet flange from the elbow fitted to the bellows. Immediately fit the blanking cap (not shown) to the cartridge inlet after you have disconnected the cartridge inlet from the elbow.
- After Step 2 of Section 5.4.4: use a suitable spanner or wrench to disconnect the rigid air tuyere pipe (10) from the air tuyere inlet on the cartridge (4).
- Before Step 1 of Section 5.4.5, remove the blanking cap (24) from the cartridge outlet (21), and remove the blanking cap (not shown) from the cartridge inlet.
- In Section 5.4.5, ignore Step 8 (as the elbow and flexible bellows remain fitted in the M150 enclosure); instead, reconnect the rigid air tuyere pipe (10) to the air tuyere inlet on the cartridge (4).
- After Step 10 of Section 5.4.6: fit the quick-release connector (6) on the end of the flexible air-tuyere pipe (7) to the quick-release connector (5) on the enclosure.

A5.5.4 Fault finding

Refer to Table A5-2 for fault finding.

A5.6 Disposal of used cartridges

WARNING

The contents of used C150JV cartridges contain arsenic and are very dangerous. Wear suitable safety clothing when you handle used C150JV cartridges. Dispose of used C150JV cartridges in accordance with all local and national safety requirements.

Safely dispose of used C150JV and C150R cartridges: refer to Section 6.2.2.

Symptom	Check	Action
You cannot obtain an air flow of 5 slm, as shown on the flow-meter.	<p>Is the compressed air supply connected and of the correct pressure ?</p> <p>Is the flexible air tuyere pipe correctly fitted ?</p> <p>Is there a leak in the flexible air tuyere pipe ?</p>	<p>Check and correct as necessary.</p> <p>Ensure that the quick-release connector on the pipe is correctly fitted to the connector on the enclosure and check that the compression connector on the other end of the pipe is correctly fitted to the air tuyere pipe on the cartridge.</p> <p>If the pipe is correctly fitted, there may be a leak in the pipe. Remove the pipe and leak test it. If the pipe leaks, you must replace it.</p>

Table A5-2 - Air tuyere fault finding

APPENDIX A6 INLET PRESSURE DISPLAY ORDERING OPTION

A6.1 Description

A6.1.1 Principle of operation

This installation option allows you to monitor the pressure in the M150 inlet pipeline.

Refer to Figure A6-1. A pressure transducer (3) monitors the pressure in the M150 inlet pipeline. The outputs of the pressure transducer are connected to the interface PCB (printed circuit board). The interface PCB is connected to the display (1), which shows the inlet pressure.

Purge nitrogen prevents blockage of the transducer, and the pipeline to the transducer, by deposits from the process gases.

A6.1.2 Installation details

Figure A6-1 shows the components on the inlet pipeline and the location of the inlet pressure display on the control unit. Note that this display is similar to the M150 cartridge temperature controllers.

A6.2 Technical data

Operating pressure range	-0.5 to 1.0 bar gauge, 0.5×10^5 to 2×10^5 Pa
Mass of inlet pressure display components	1 kg

A6.3 Operation

When the M150 is switched on, the display (Figure A6-1, item 1) will continuously show the pressure (in mbar) in the M150 inlet pipeline.

A6.4 Maintenance

A6.4.1 Re-enter the operating parameters into the inlet pressure display

To re-enter the operating parameters into the inlet pressure display, use the same procedures as for the M150 cartridge temperature controllers (refer to the M150 instruction manual). The inlet pressure display operating parameters are shown in Table A6-1.

Level	Function	Option
1	tunE	oFF
	bAnd	10
	int.t	5.0
	dEr.t	25
	dAC	1.5
	CyC.t	oN.oFF
	oFSt	0
	SPLk	oN
	SEt.2	0
	BAND.2	2.0
	CyC.2	oN.oFF
2	SP!.P	100
	hAnd	oFF
	PL.1	0
	PL.2	0
	SP2.A	none
	SP2.b	none
	diSP	1
	hiSC	1000
	LoSC	0
3	SP1	SSD
	SP2	RLY
	UPSC	BURN
	REV.d	1r.2d
	rGL	1n.2n
	SPAN	0
	ZERO	*
	cheK	oFF
	read	VAr
	DATA	ctA
	VER	1 or Lock
	reset	none

* Each transducer will give a different value at normal atmospheric pressure. To zero the display, enter - (the value read). For example, if the value read is -2, enter +2 to zero the display.

Table A6-1 - Inlet pressure display operating parameters

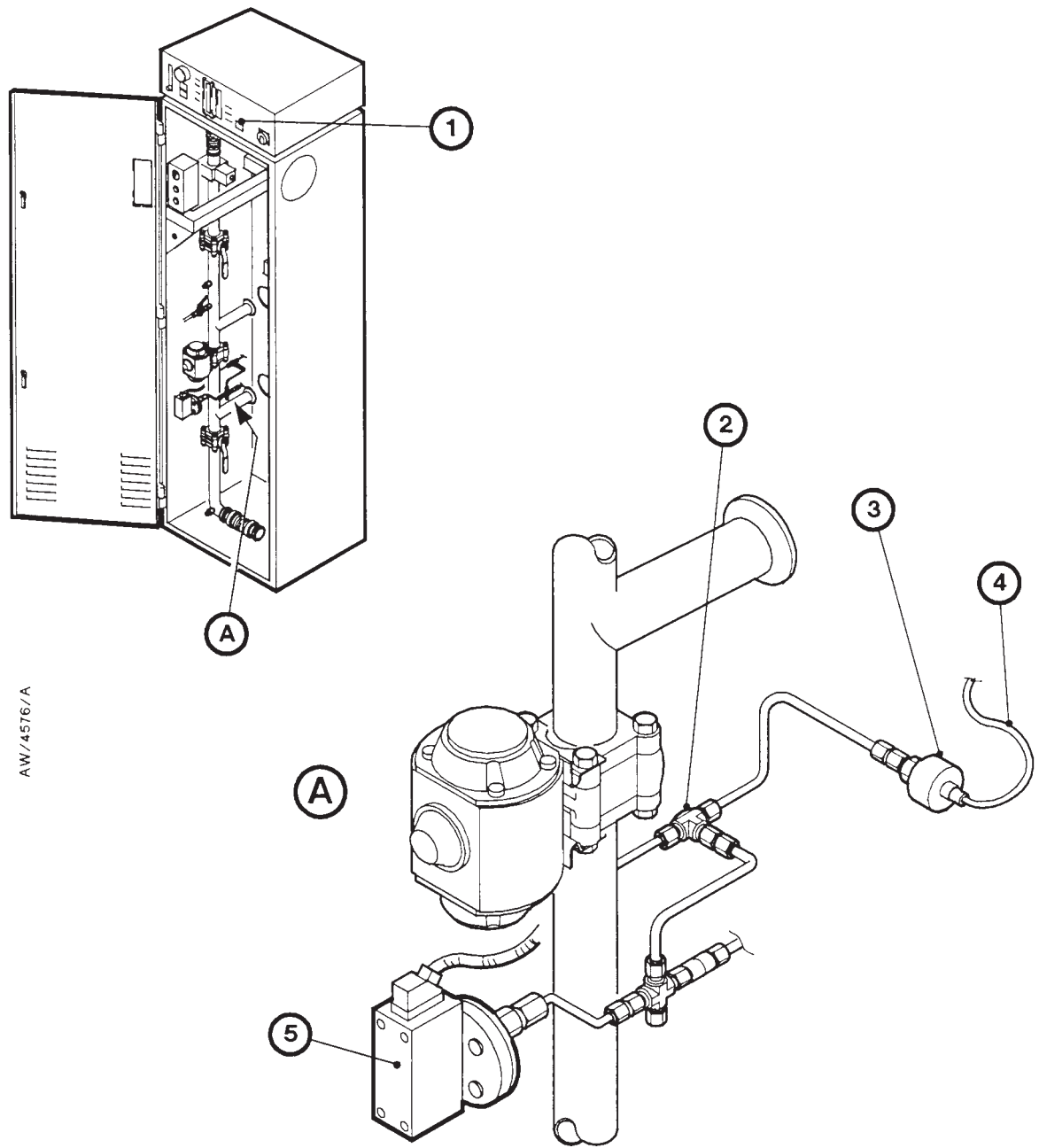

1. Inlet pressure display
2. Swagelok 'T' piece
3. Pressure transducer
4. Electrical cable
5. Pressure-switch unit

Figure A6-1 - Inlet pressure display components

A6.4.2 Fault finding

Symptom	Check	Action
The pressure shown on the display is increasing rapidly, or 'InPt FAIL' is displayed.	<p>Is the pressure transducer disconnected from the interface PCB ?</p> <p>Is the interface PCB disconnected from the control unit ?</p> <p>Is the pressure transducer faulty ?</p>	<p>Ensure that the pressure transducer is correctly connected to the interface PCB.</p> <p>Check that the interface PCB is correctly connected to the M150 control unit.</p> <p>If all the connections are correct, the pressure transducer may be faulty: contact your supplier or BOC Edwards for advice.</p>
'InPt nOnE' is shown on the display.	Is the controller unprogrammed or have the operating parameters been corrupted ?	Re-enter the operating parameters into the inlet pressure display as described in Section A6.4.1.
The display is blank.	Is the display disconnected from the control unit ?	Check that the display is correctly connected to the electrical supply in the M150 control unit.

Table A6-2 - Inlet pressure display fault finding

APPENDIX A7 AUDIBLE ALARM ORDERING OPTION

A7.1 Description

Refer to Figure A7-1. You will fit the audible alarm to the side of the control unit, and connect it to the M150 control unit through the audible alarm connector (2). The audible alarm has a loudspeaker (6) which emits an alarm tone when any of the red alarm LEDs on the M150 status display are on.

The audible alarm has a cancel button (7). If the audible alarm is on, press this button to silence the alarm for a preset time. You can adjust this time: refer to Section A7.3.3.

A7.2 Technical data

Mass	1 kg
Timer accuracy	0.5% of full range
Timer reset time	100 ms
Timer setting accuracy	± 10%

A7.3 Additional installation requirements

A7.3.1 Unpack and inspect

When you unpack and inspect the M150 (as described in the M150 instruction manual), check that you have received the additional components shown in Table A7-1. If any component is missing, notify the supplier in writing within three days.

Qty	Description	Check (✓)
1	Audible alarm	<input type="checkbox"/>
2	Spacers	<input type="checkbox"/>
2	Fixing screws	<input type="checkbox"/>

Table A7-1 - Audible alarm components

A7.3.2 Fit the audible alarm

Refer to Figure A7-1 and use the following procedure to install the audible alarm.

1. Remove the cover from the M150 control unit (5): refer to Section 3.8.
2. Use the fixing screws (4) to secure the audible alarm to the side of the M150 control unit (5). Ensure that the spacers (3) are between the audible alarm and the control unit, as shown in Figure A7-1.
3. Refit the cover to the control unit (5): refer to Section 3.8.
4. Fit the electrical connector (1) on the end of the audible alarm cable to the audible alarm connector (2) on the top of the M150 control unit.
5. If required, adjust the alarm on and release timers: refer to Section A7.3.3.

A7.3.3 Adjust the alarm on and cancel timers (optional)

Refer to Figure A7-1. The audible alarm has two timers (see detail B):

- One timer (13) controls the delay between when an M150 alarm LED goes on and the audible alarm goes on. The alarm on delay control (10) is preset to 'release delay' and the timer controls (11, 12) are preset to 20 seconds.
- The other timer (14) controls the time that the alarm remains off when you press the alarm cancel button. The alarm cancel delay control (17) is preset to 'on delay' and the timer controls (15, 16) are preset to 15 minutes.

Refer to Figure A7-1 and use the following procedure to adjust a timer:

1. Undo and remove the four screws (8) and remove the cover (9) of the audible alarm.
2. To change the delay between when an M150 alarm LED goes on and the audible alarm goes on, adjust the alarm on timer controls (11, 12) to the required delay time. Do **not** adjust the alarm cancel delay control (10).
3. To change the time that the alarm remains off when you press the alarm cancel button, adjust the alarm cancel timer controls (15, 16) to the required time. Do **not** adjust the alarm cancel delay control (17).
4. Refit the cover (9) and secure with the four screws (8).

A7.4 Operation

The audible alarm will go on a preset time after an alarm LED on the M150 goes on. When the audible alarm goes on, take the appropriate action to correct the alarm fault.

If required, press the alarm cancel button (Figure A7-1, item 7) to silence the alarm. When you press the alarm cancel button, the lamp in the button goes on and the audible alarm will remain off for a preset time (see Section A7.3.3). At the end of that time, if an alarm condition still exists, the lamp in the button will go off and the audible alarm will go on again.

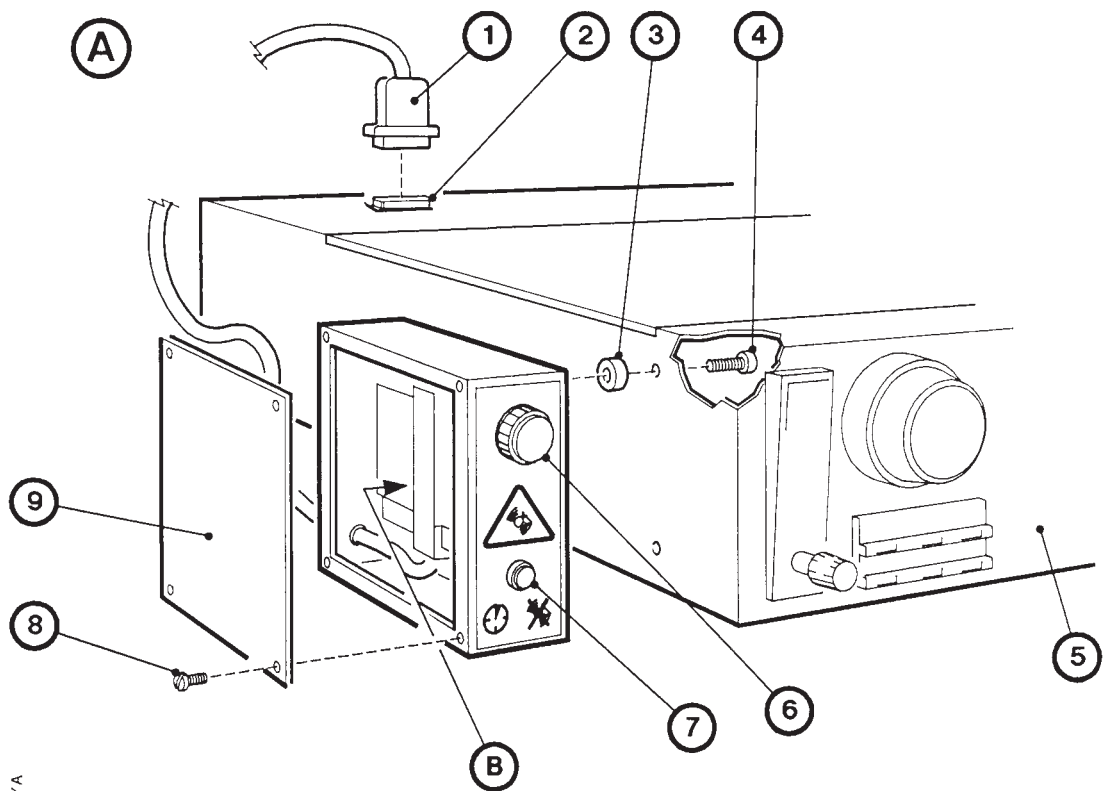

AW/4580/A

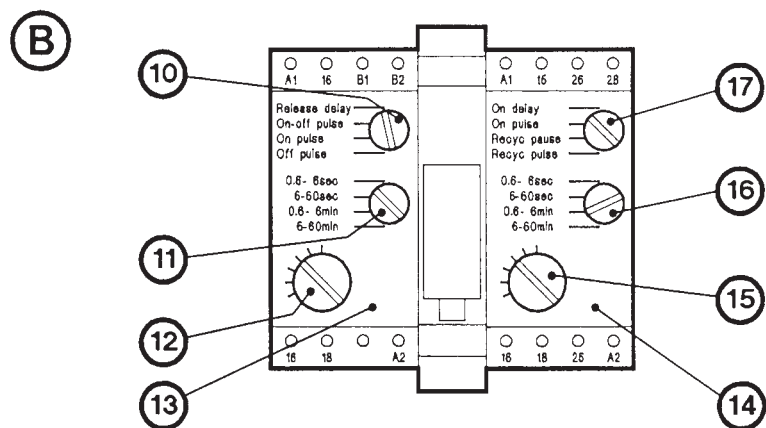

- | | |
|----------------------------|--------------------------------------|
| 1. Electrical connector | 10. Alarm on delay control |
| 2. Audible alarm connector | 11. Alarm on timer range control |
| 3. Spacer | 12. Alarm on timer time control |
| 4. Screw | 13. Alarm on timer |
| 5. M150 control unit | 14. Alarm cancel timer |
| 6. Loudspeaker | 15. Alarm cancel timer time control |
| 7. Alarm cancel button | 16. Alarm cancel timer range control |
| 8. Screw | 17. Alarm cancel delay control |
| 9. Cover | |

Figure A7-1 - Fit the audible alarm

A7.5 Maintenance

A7.5.1 Regular maintenance

The audible alarm requires no additional regular maintenance.

A7.5.2 Fault finding

Symptom	Check	Action
An M150 alarm LED is on, but the audible alarm is not on.	Is the alarm on delay too long ? Is the audible alarm disconnected or is it faulty ?	Check that the alarm on delay is not set to too long a delay. If necessary, change the delay: refer to Section A7.3.3. Check that the audible alarm connector is correctly connected to the remote fault connector on the control unit. If the connector is correctly connected, the audible alarm may be faulty: contact your supplier or BOC Edwards.
The audible alarm does not go off when you press the alarm cancel button.	Is the alarm cancel delay too short ?	Check that the alarm cancel delay is not too short. If necessary, change the delay: refer to Section A7.3.3. If the alarm cancel delay is correct, the audible alarm may be faulty: contact your supplier or BOC Edwards.

Table A7-2 - Audible alarm fault finding

APPENDIX A8 PREHEAT STATION ORDERING OPTION

A8.1 Introduction

A8.1.1 Description

The Preheat Station is a modified M150 GRC, and is used to preheat M150 GRC cartridges to operating temperature. If you replace a used cartridge in the M150 GRC with a new cold cartridge, it takes approximately 60 to 90 minutes for the cartridge to heat up to its correct operating temperature and start to treat the process gases. When you use the Preheat Station to heat a new cartridge to its correct operating temperature and then replace the heater unit with the used cartridge in the GRC with the preheated heater unit and new cartridge, the time taken to start to treat process gases is reduced to approximately ten minutes.

Refer to Figure A8-1. The Preheat Station has a ventilated enclosure (7) with a control unit (1) and a lower control panel (11). The heater unit (6) contains the cartridge to be heated. The heater unit is fully enclosed by the ventilated enclosure. The enclosure prevents accidental contact with hot components.

When the Preheat Station is switched on, the cartridge is heated and dry nitrogen is passed through the cartridge, to ensure the even distribution of heat throughout the cartridge.

A8.1.2 Control unit configuration

The control unit of the Preheat Station is similar to that on the standard M150 GRC (refer to Figure 1-5), except that:

- There are no TMS temperature controllers or inlet pressure monitoring display.
- The status display is different: refer to Section A8.1.3.

Refer to Figure 3-2. The Preheat Station only has the following connections on the top of the control unit:

- Remote fault connector (5).
- Nitrogen supply connector (10).
- Electrical supply cable-gland (11).

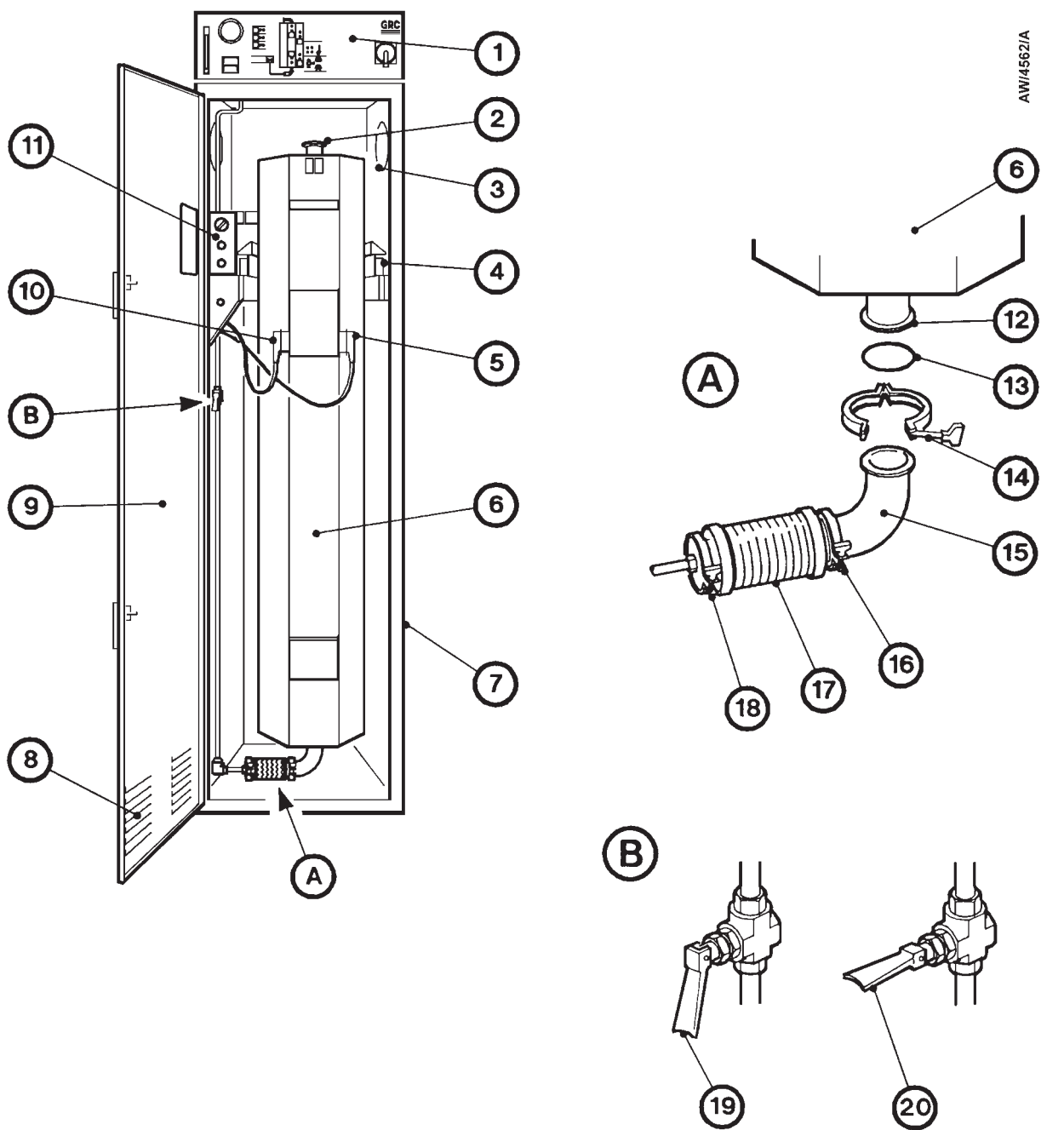

- | | | |
|----------------------------|--------------------------|-----------------------------------|
| 1. Control unit | 8. Ventilation grills | 15. Cartridge inlet elbow |
| 2. Cartridge outlet | 9. Door | 16. Clamp and trapped 'O' ring |
| 3. Cabinet extraction port | 10. Electrical connector | 17. Flexible bellows |
| 4. Roller carriage | 11. Lower control panel | 18. Clamp and trapped 'O' ring |
| 5. Electrical connector | 12. Cartridge inlet | 19. Nitrogen purge valve (open) |
| 6. Heater unit | 13. Trapped 'O' ring | 20. Nitrogen purge valve (closed) |
| 7. Enclosure | 14. Clamp | |

Figure A8-1 - Components of the Preheat Station

A8.1.3 Status display

The status display on the Preheat Station is shown in Figure A8-2. The display has red and green LEDs (see Table 2). In normal operation, only green (status) LEDs should be on; a red (fault) LED indicates a fault condition. The red LEDs go on or flash when a fault is present. For a full description of fault finding when a red fault LED goes on or flashes, refer to Section A8.5.3.

Figure key	LEDs Name	Meaning
10	Earth leakage trip	These LEDs are only used if you have the earth leakage trip accessory in your Preheat Station: refer to the instruction manual supplied with the accessory.
9	Circuit breaker	The green LED is on when the Preheat Station is connected to the electrical supply and is switched on. The red LED flashes when the Preheat Station is connected to the electrical supply and the circuit breaker has tripped to shut down the Preheat Station.
8	Nitrogen purge	The green LED is on when the flow of nitrogen to the cartridge is within acceptable limits. The red LED flashes when the flow of nitrogen to the cartridge is too low.
7	Lower cartridge temperature	The green LED is on when the cartridge thermocouples indicate that the temperature of the bottom of the cartridge is within acceptable limits. The red LED flashes when the thermocouples indicate that the temperature of the bottom of the cartridge is too high or too low. (Refer to Section 1.4).
6	Lower heater temperature	The green LED is on when the heater thermocouple indicates that the temperature of the single heater in the bottom of the heater unit is in acceptable limits. The red LED flashes when the thermocouple indicates that the temperature of the heater is too low (refer to Section 1.4).
5	Timer	This red LED flashes when the timer to cancel the beacon is operating; that is, the cancel button has been pressed.
4	Remote fault output	The upper and lower green LEDs are on when the Preheat Station is operating correctly. When there is a warning condition, the upper green LED goes off and the upper red LED goes on. When there is an alarm condition, the lower green LED goes off and the lower red LED goes.
3	Phase balance monitor	These LEDs are only used on the Preheat Station model E. The green LED is on when the currents (drawn by the upper heaters) on the three phases of the electrical supply are in balance. The red LED flashes when the currents are out of balance: see Section 1.8.

Table A8-1 - Status display LEDs

Figure key	LEDs Name	Meaning
2	Upper cartridge temperature	The green LED is on when the cartridge thermocouples indicate that the temperature of the top of the cartridge is within acceptable limits. The red LED flashes when the thermocouples indicate that the temperature of the top of the cartridge is too high or too low (see Section 1.3).
1	Heater power	The green LED is on during normal operation. The red LED flashes when the electrical supply to the heaters is interrupted.

Table A8-1 - Status display LEDs (continued)

A8.2 Technical data

Note: Unless otherwise specified below, the technical data for the standard M150 GRC also applies to the Preheat Station.

Mass

Enclosure and control unit	92 kg
Heater unit (without cartridge)	64 kg
C150Y cartridge (unused)	39 kg
Total	195 kg
Nitrogen supply pressure	3 to 5 bar gauge (4 to 6 bar absolute)
Nominal regulated flow rate to cartridge	7.5 l.min ⁻¹

A8.3 Installation

Use the procedures in Section 3 of this manual to install the Preheat Station, with the following exceptions:

- Note that in Section 3.2, the system design requirements concerning total gas flow into the cartridge do not apply to the Preheat Station.
- When you unpack and inspect the Preheat Station (in Section 3.3), note you will receive three NW40 clamping rings and three NW40 trapped 'O' rings.
- In Section 3.7, you will only need to connect a nitrogen supply to the Preheat Station.
- You do not need to connect the inlet and outlet as described In Section 3.10.
- In Section 3.11, fit a cartridge to the heater unit and fit the heater unit (and cartridge) in the Preheat Station enclosure as described in Section A8.4.4.
- You do not need to fit pump exhaust TMS components, ordering option components or accessories as described in Sections 3.13 to 3.15.

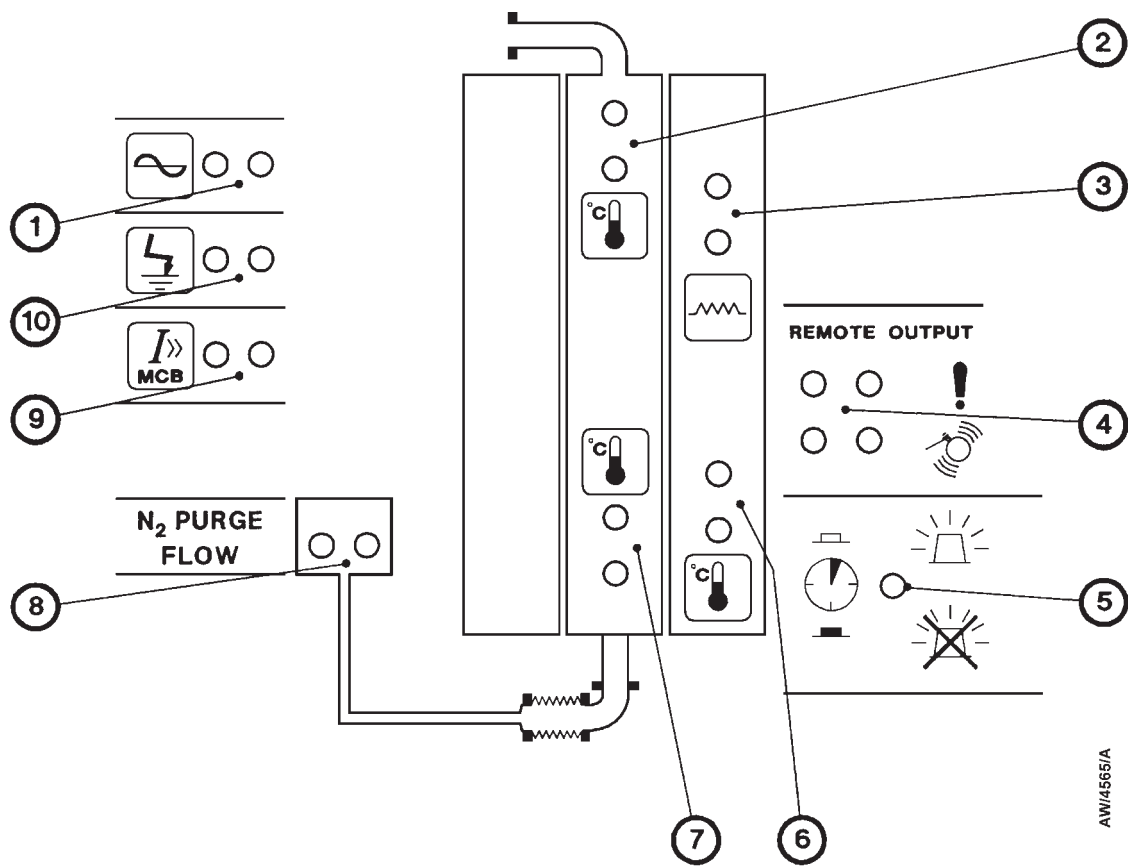

AW/4565/A

- | | |
|-------------------------------------|-------------------------------------|
| 1. Heater power LEDs | 6. Lower heater temperature LEDs |
| 2. Upper cartridge temperature LEDs | 7. Lower cartridge temperature LEDs |
| 3. Phase balance monitor LEDs † | 8. Nitrogen purge LEDs |
| 4. Remote fault output LEDs | 9. Circuit breaker LEDs |
| 5. Timer LED | 10. Earth leakage trip LEDs * |

* Only used if the corresponding accessory is fitted to the Preheat Station

† Only used on the Preheat Station model E

Figure A8-2 - Control panel status display

A8.4 Operation

A8.4.1 Start-up

Note: If you want to switch off the alarm beacon while the cartridge warms up, press the alarm cancel button on the control unit (Figure 5, item 12).

1. Refer to Figure 1-5. Ensure the electrical supply isolator (4) is in the off position.
2. Refer to Figure A8-1. Turn on your nitrogen supply and move the nitrogen purge valve to the open position (19); ensure that the supply pressure is between 1.5 and 2 bar gauge (2.5 and 3 bar absolute) and that a flow of approximately $7.5 \text{ l}\cdot\text{min}^{-1}$ is shown on the flowmeter on the control unit (Figure 1-5, item 9).
3. Refer to Figure 1-5. Switch on the electrical supply and switch on the electrical supply isolator on the control unit (4).
4. Switch on the heater power switch (10) on the lower control unit.
5. Press the reset button (11) on the lower control panel. The cartridge temperature controllers (6, 7) will then go blank for approximately five seconds and then change to show the temperature of the cartridge.

Refer to Figure 1-7. The temperature alarm LEDs (3) on the cartridge temperature controllers should be on to indicate that the cartridge is outside the operating temperature range, and the green heater LEDs (1) should be on to indicate that the heaters are operating to warm up the cartridge.

6. Only green LEDs on the status display (Figure A8-2) should then be on, with the exception of the temperature LEDs (items 2, 6 and 7); the red temperature LEDs will flash to indicate that the cartridge and the heater are below operating temperature.
7. The Preheat Station will now heat up to its operating temperature which is reached after 60 to 90 minutes. When the temperature of the cartridge is in the operating temperature range, the red temperature alarm LEDs on the temperature controllers will go off.

A8.4.2 Remove the heater unit and exhausted cartridge from the M150 GRC

1. Remove the heater unit (with the exhausted cartridge) from the M150 enclosure: refer to Section 5.4.3.
2. Leave the heater unit and cartridge to cool for at least 24 hours.

A8.4.3 Remove the heater unit from the Preheat Station and fit it to the M150 GRC

WARNING

The cartridge outlet, clamp and bellows will be hot (approximately 200 °C). Wear thermal protective gloves when you remove the heater unit from the Preheat Station and fit the heater unit in the M150; do not touch any of the components with your bare skin.

1. Refer to Figure 1-5. Use the heater power switch (10) on the lower control panel of the Preheat Station to switch off the electrical supplies to the heater unit. The alarm beacon (1) will go on.
2. Refer to Figure A8-1. Open the door (9) of the enclosure and move the nitrogen purge valve to the closed position (19).
3. Disconnect the electrical connectors (5, 10) from the heater unit.
4. Refer to Figure 5-2. Remove the thermocouple connectors on the cartridge (1) from the thermocouple connectors (2) on the heater unit extension leads.
5. Put on thermal protective gloves; wear these gloves throughout the remainder of this procedure.
6. Refer to Figure A8-1. Remove the clamp (18) which secures the braided flexible bellows (17) to the nitrogen pipeline and remove the trapped 'O' ring.
7. Ensure that the cartridge change cart is in the upright position (see Figure 1-9, detail A).
8. Refer to Figure 5-3. Ensure that the heater unit support arms are in the vertical position (5).
9. Push the cartridge change cart in front of the heater unit, then turn the two support arms (8) so that the pins (9) under the arms go into the holes (11) in the enclosure frame.
10. Press and hold the heater release button (10) and pull the handle (3) on the heater unit to slide the heater unit (2) on its roller bearings (4) onto the cartridge change cart (7).
11. Refer to detail B. Slide the heater unit (2) fully onto the cartridge change cart (7). The catch (6) will then automatically secure the heater unit on the change cart.
12. Lift up the support arms into the vertical position (5) and move the cartridge change cart to the location of the M150 GRC.
13. Fit the heater unit to the M150 GRC: refer to Section 5.4.6; ensure that you wear thermal protective gloves when you fit the heater unit.
14. Restart the M150 GRC: refer to Section 5.4.7.

A8.4.4 Fit a new cartridge to the heater unit and refit in the Preheat Station

1. Fit a new cartridge to the heater unit: refer to Section 5.4.5.
2. Fit the heater unit to the Preheat Station: use the procedure in Section 5.4.6, but note that in Step 7, you do not need to connect an elbow to the cartridge outlet.
3. Restart the Preheat Station: refer to Steps 2 to 7 of Section A8.4.1.

A8.5 Maintenance

A8.5.1 Maintenance plan

The only maintenance required for the Preheat Station is as shown in Table A8-2 below.

Operation	Frequency	Refer to Section
Check the nitrogen gas flow	Daily	A8.5.2
Replace the thermal fuses	As necessary	5.7
Adjust the cartridge temperature controllers	As necessary	5.8
Adjust the heater controllers	As necessary	5.9

Table A8-2 - Maintenance plan

A8.5.2 Check the nitrogen gas flow

When the Preheat Station is in use and at operating temperature, check that there is a reading of approximately $7.5 \text{ l}\cdot\text{min}^{-1}$ on the nitrogen flow-meter (Figure 1-5, item 9) on the control unit. If necessary, adjust the flow-control valve (8).

A8.5.3 Fault finding

Use the procedures in Section 5.11 for fault finding, but refer to Table A8-3 before you refer to Table 5-3.

Symptom	Check	Action
A temperature warning is shown on a cartridge temperature controller: the temperature is too low (and a new cartridge has been fitted and heated for two hours or more).	Is the nitrogen gas flow through the Preheat Station too high ? Has a heater failed ? Is a thermocouple faulty ?	Ensure that the gas flow is 7.5 l.min ⁻¹ . Refer to Table 5-3. Refer to Table 5-3.
The red nitrogen flow alarm LED is on.	Has the nitrogen supply failed or is the pressure of the supply too low ? Is the nitrogen purge valve closed ? Is a nitrogen pipe disconnected ?	Check the nitrogen supply. The supply pressure must be as specified in Section A8.2. Ensure that the nitrogen purge valve is open. Check the pipes; reconnect any disconnected pipe.
A red cartridge temperature LED is on.	Is the nitrogen flow through the Preheat Station too high ? Has a heater failed ?	Ensure that the nitrogen flow is 7.5 l.min ⁻¹ . Check the currents drawn by the heaters (refer to Section 5.12.2).
The red lower heater temperature LED goes on periodically.	Is the nitrogen flow through the cartridge too low ?	With a very low nitrogen flow through the cartridge, the lower heaters may cool and trip the alarms before the lower zone of the cartridge has cooled sufficiently to switch on the lower heater again. Ensure that the nitrogen flow is 7.5 l.min ⁻¹ .

Table A8-3 - Preheat Station fault finding

(This page deliberately left blank)

APPENDIX A9 REMOTE DISPLAY ACCESSORY

A9.1 Description

The Remote Display accessory allows you to monitor and control the operation of the M150, in a location remote from the M150 enclosure.

Refer to Figure A9-1. The Remote Display (4) can be hand-held, or can be placed on a suitable surface up to 10 metres from the M150 enclosure.

Refer to detail B. The front panel of the Remote Display has the following indicators and controls:

Reset button (6)	This operates in exactly the same way as the reset button on the M150 lower control panel: refer to Section 1.6.1.
Status display (7)	This operates in exactly the same way as the status display on the M150 control unit: refer to Section 1.6.2.
Beacon cancel button (8)	This operates in exactly the same way as the beacon cancel button on the M150 lower control panel: refer to Section 1.6.1.

A9.2 Installation

A9.2.1 Fit the Remote Display

Use the following procedure to install the Remote Display accessory:

1. Refer to Figure A9-1. Fit the plug (1) on the end of the cable to the remote display connector (5) on the top of the control unit.
2. Place the Remote Display (4) in its required operating location.

A9.2.2 Connect to an alarm beacon (optional)

If required, you can connect an alarm beacon to the Remote Display; the alarm beacon will go on when any of the red alarm LEDs on the Remote Display (and on the M150 status display) are on.

Use the following procedure to connect an alarm beacon to the Remote Display:

1. Connect a suitable two-core cable to pins 1 and 3 of a three-pin DIN plug.
2. Connect the wires at the other end of the cable to your alarm beacon.
3. Refer to Figure A9-1. Fit the DIN plug to the beacon connector (3) on the top of the Remote Display (4).

A9.3 Regular maintenance

The remote display accessory requires no additional regular maintenance.

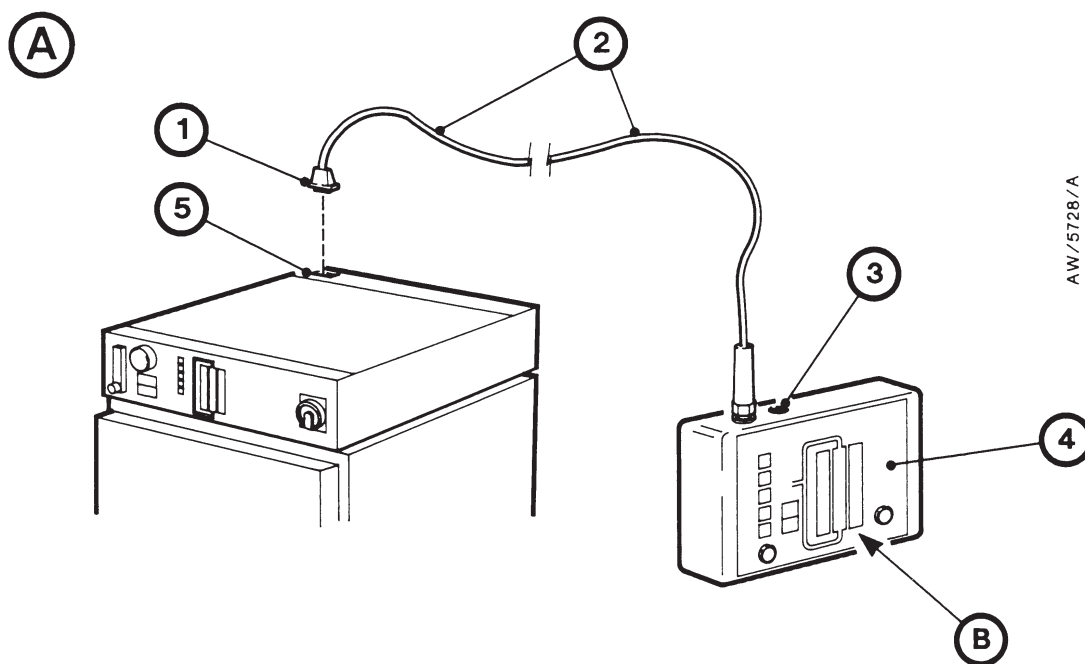

AW/5728/A

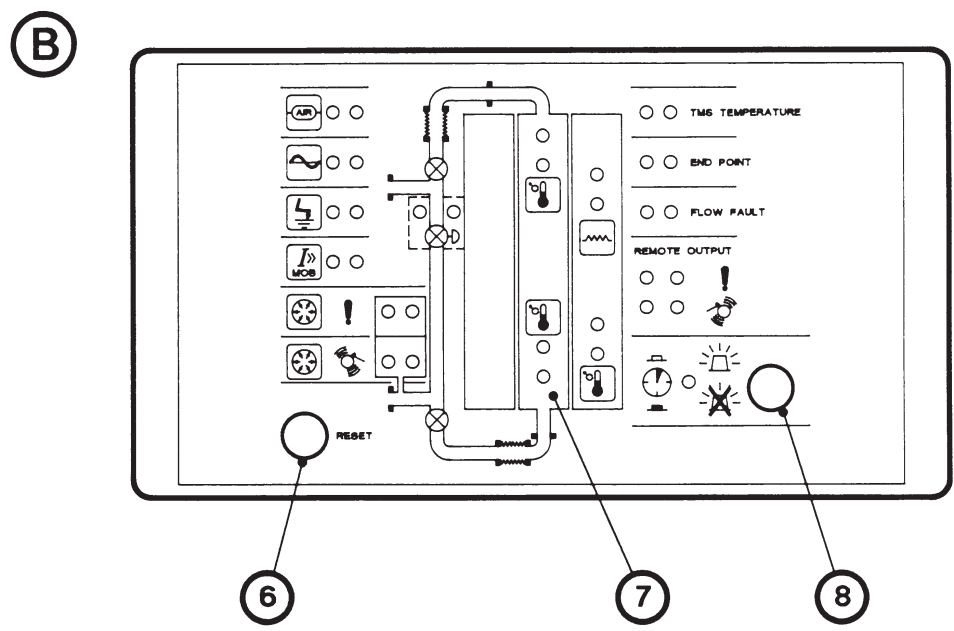

- | | |
|---------------------|-----------------------------|
| 1. Plug | 5. Remote display connector |
| 2. Cable | 6. Reset button |
| 3. Beacon connector | 7. Status display |
| 4. Remote Display | 8. Beacon cancel button |

Figure A9-1 - Fit the Remote Display

APPENDIX A10 CONVERSION TABLES

	$\text{l}\cdot\text{min}^{-1}$	$\text{ft}^3\cdot\text{min}^{-1}$	m^3h^{-1}	$\text{imp gal}\cdot\text{h}^{-1}$	$\text{US gal}\cdot\text{h}^{-1}$
$1 \text{ l}\cdot\text{min}^{-1} =$	1	0.0353	0.06	16.67	15.85
$1 \text{ ft}^3\cdot\text{min}^{-1} =$	28.32	1	1.7	3.734	4.486
$1 \text{ m}^3\text{h}^{-1} =$	16.67	0.589	1	2.1997	2.642
$1 \text{ imp gal}\cdot\text{h}^{-1} =$	0.076	0.2678	0.4546	1	1.201
$1 \text{ US gal}\cdot\text{h}^{-1} =$	0.063	0.2229	0.3785	0.833	1

Table A10-1 - Volumetric flow rate unit conversions

	mm	cm	m	in	ft
$1 \text{ mm} =$	1	0.1	0.001	0.0394	3.28×10^{-3}
$1 \text{ cm} =$	10	1	0.01	0.3937	3.28×10^{-2}
$1 \text{ m} =$	1000	10	1	39.37	3.2808
$1 \text{ in} =$	25.4	2.54	0.0254	1	8.33×10^{-2}
$1 \text{ ft} =$	304.8	30.48	0.305	12	1

Table A10-2 - Linear unit conversions

Unit/function	Equivalent/formula
Centigrade ($^{\circ}\text{C}$) to Fahrenheit ($^{\circ}\text{F}$)	$^{\circ}\text{F} = (^{\circ}\text{C} \times \frac{9}{5}) + 32$
Fahrenheit ($^{\circ}\text{F}$) to Centigrade ($^{\circ}\text{C}$)	$^{\circ}\text{C} = \frac{5}{9} \times (^{\circ}\text{F} - 32)$

Table A10-3 - Temperature conversions

	psi	atm.	inch H ₂ O	mm H ₂ O	cm H ₂ O	oz.inch ⁻²	kg.cm ⁻²	inch Hg	mm Hg (Torr)	cm Hg	mbar	bar	Pa (N.m ⁻²)	kPa	MPa
1 psi =	1	0.0681	27.71	703.8	70.38	16	0.0704	2.036	51.715	5.17	68.95	0.0689	6895	6.895	0.0069
1 atm =	14.7	1	407.2	10,343	1,034.3	235.1	1.033	29.92	760	76	1013	1.013	101,325	101.3	0.1013
1 inch H ₂ O =	0.0361	0.00246	1	25.4	2.54	0.5775	0.00254	0.0735	1.866	0.187	2.488	0.00249	248.8	0.249	0.00025
1 mm H ₂ O =	0.001421	0.000097	0.0394	1	0.1	0.0227	0.0001	0.00289	0.0735	0.00735	0.098	0.000098	9.8	0.0098	0.00001
1 cm H ₂ O =	0.01421	0.000967	0.3937	10	1	0.227	0.001	0.0289	0.735	0.0735	0.98	0.00098	98	0.098	0.0001
1 oz.inch ⁻² =	0.0625	0.00425	1.732	43.986	4.4	1	0.0044	0.1273	3.232	0.323	4.31	0.00431	431	0.431	0.00043
1 kg.cm ⁻² =	14.22	0.968	394.1	100,010	1,001	227.6	1	28.96	735.6	73.56	980.7	0.981	98,067	98.07	0.0981
1 inch Hg =	0.4912	0.03342	13.61	345.7	34.57	7.858	0.0345	1	25.4	2.54	33.86	0.0339	3386	3.386	0.00339
1 mm Hg (Torr) =	0.01934	0.001316	0.536	13.61	1.361	0.310	0.00136	0.0394	1	0.1	1.333	0.001333	133.3	0.1333	0.000133
1 cm Hg =	0.1934	0.01316	5.358	136.1	13.61	3.1	0.0136	0.394	10	1	13.33	0.01333	1333	1.333	0.00133
1 mbar =	0.0145	0.000987	0.4012	10.21	1.021	0.2321	0.00102	0.0295	0.75	0.075	1	0.001	100	0.1	0.0001
1 bar =	14.504	0.987	401.9	10,210	1021	232.1	1.02	29.53	750	75	1000	1	100,000	100	0.1
1 Pa (N.m ⁻²) =	0.000145	0.00001	0.00402	0.102	0.0102	0.00232	0.00001	0.000295	0.0075	0.00075	0.01	0.00001	1	0.001	0.000001
1 kPa =	0.14504	0.00987	4.019	102.07	10.207	2.321	0.0102	0.295	7.05	0.75	10	0.01	1,000	1	0.001
1 MPa =	145.04	9.869	4019	102,074	10,207	2321	10.2	295.3	7500	750	10,000	10	1,000,000	1,000	1

Table A10-4 - Pressure unit conversions

GRC APPLICATION FORM

(Form GRC1)

So that we can provide accurate advice on the use of the Gas Reactor Column on your applications, please photocopy this form and complete Section 1 (Application Data) in block capital letters, then return the complete form to your supplier or to the following address:

BOC Edwards
 Exhaust Management Group
 Southfield Road Trading Estate
 NAILSEA
 United Kingdom BS48 1JJ

Telephone : +44 (0) 1275 811200

Facsimile : +44 (0) 1275 810256

Section 2 (GRC Recommendations) will then be completed by our application engineers and the form will be returned to you.

SECTION 1 : APPLICATION DATA

Process: _____		Model: _____		
Process Machine Make: _____		Model: _____		
Pump Make: _____		Model: _____		
Oil Used: _____		Total N ₂ Purge: _____		
	Gas type	Gas flow: sccem	Gas on time per wafer or batch	Wafers or batches per month
Process Step 1	1			
	2			
	3			
	4			
Process Step 2	1			
	2			
	3			
	4			
Process Step 3	1			
	2			
	3			
	4			

Your name: _____ Your job title: _____
 Your organisation: _____
 Your address: _____
 Telephone number: _____
 Signed: _____ Date: _____

SECTION 2 : BOC EDWARDS RECOMMENDATIONS

We recommend that you use the following cartridge type on your application: _____

On the application and gas flows specified in section 1 above, cartridge lifetime is predicted to be between: _____ and _____ weeks

Temperatures should be set as follows: Upper: _____ Lower: _____

Signed: _____ Date: _____
 Name: _____ Job Title: _____

GRC INSTALLATION APPLICATION FORM (Form GRC2)

So that we can arrange for installation and commissioning of your GRC at a suitable time, please photocopy this form and complete Sections 1 and 2 (in block capital letters), then return the complete form to your supplier or to the following address:

BOC Edwards
Exhaust Management Group
Southfield Road Trading Estate
NAILSEA
United Kingdom BS48 1JJ

Telephone : +44 (0) 1275 811200

Facsimile : +44 (0) 1275 810256

SECTION 1 : COMPANY INFORMATION

Customer Name (Company) : _____

Customer Address : _____

Customer Contact name : _____

Customer Contact Telephone Number : _____

BOC Edwards Contact Name : _____

BOC Edwards Contact Telephone Number : _____

GRC Model and Serial Number : _____

Date on which commissioning is requested : _____

SECTION 2 : COMMISSIONING APPROVAL

We confirm that we have prepared a site suitable for installation of the GRC in accordance with the recommendations in the following sections of the GRC instruction manual:

- SECTION 2 - TECHNICAL DATA
- SECTION 3 - INSTALLATION

We also confirm that we request installation and commissioning of the GRC, and that free access will be provided to the installation site, on the date given in Section 1 above.

Print your name : _____

Job Title : _____

Signed : _____

Date : _____

GRC WAFER/EVC TREATMENT RECORD (Form GRC4)

Process type :				System identifier/location:				
GRC serial number :								
Order of use	Cartridge serial number	Days on-line	Actual wafer throughput	EVC treated (calculated from wafer throughput)	Initial cartridge change cart weight	Cartridge change cart weight increase	Number of wafers treated (calculated from weight gain)	EVC treated (calculated from weight gain)
1								
2								
3								
4								
5								
6								
7								
8								
9								
10								
11								
12								
13								
14								
15								
16								
17								
18								
19								
20								
21								
22								
23								
24								
25								
26								
27								
28								
29								
30								
Notes :								

We recommend that you regularly monitor the GRC and record the information required by this form.

If required, use this form: photocopy this page each time a new form is required, and complete the form with the necessary information during GRC use.
 If you do not use this form to record the information, you can use an equivalent form (which you must supply).

Process type :					System identifier/location:					Temperature → setpoints		Upper :
GRC serial no. :												Lower :
Date	Temp. setpoints okay *	End-point detectors okay ?	GRC on-line	Cartridge serial number	Date installed	Date on-line	Date off-line	Date removed	GRC inlet pressure	Reason for cartridge change †	Notes #	

* If the temperatures are within $\pm 5^{\circ}$ of the setpoints, tick this box.

† End-point detector breakthrough, pressure drop, time-out or manual change.

Cartridge change dates, warning and alarm messages displayed, and so forth.

