

THE
ADVANCED ENERGY®
RFX 600 GENERATOR

User Manual

ADVANCED ENERGY
INDUSTRIES, INC

1600 Prospect Parkway
Fort Collins, Colorado 80525
(303) 221-4670
Telex #45-0938

PN: 5705008-B
June 1991

To ensure years of dependable service, Advanced Energy® products are thoroughly tested and designed to be among the most reliable and highest quality systems available worldwide. All parts and labor carry our standard 1-year warranty.

For **Customer Service**, call:

AE, Colorado office	(303) 221-0108 (24-hour line) Fax: (303) 221-5583
AE, California office	(408) 263-8784 (8 a.m. to 5 p.m. Pacific Standard Time — California only) Fax: (408) 263-8992
AE, Japanese office	81 (03) 3222-1311 Fax: 81 (03) 3222-1315
AE, German office	49 (0711) 777-87-18 Fax: 49 (0711) 777-87-00
all others	contact your local service center—see the list on the next page

©1990, Advanced Energy Industries, Inc

All rights reserved. Printed in the United States of America. This manual is supplied to enable the reader to safely install, operate, and service the equipment described herein. Making copies of any part of this manual for any purpose other than these is a violation of U.S. copyright law.

In the interest of providing even better equipment, Advanced Energy Industries, Inc., reserves the right to make product changes without notification or obligation.

For more information, write Advanced Energy Industries, Inc., 1600 Prospect Parkway, Fort Collins, CO 80525.

TABLE OF CONTENTS

	Page No.
1. Safety.....	6
2. General Description.....	7
3. Specifications.....	7
4. Front Panel Display	9
5. Rear Panel Display.....	9
6. Connectors.....	10
Input Power Connectors.....	10
Analog/digital I/O Connections.....	10
Pin-description Table.....	10
Signal Descriptions.....	12
7. Diagnostic Connector Table	16
8. Dc Bias.....	17
Dc Bias Regulation.....	18
9. First Time Operation.....	20
Unpacking	20
Start-up.....	20
10. Troubleshooting.....	21
Warranty	

***** WARNING *****

SAFE OPERATING PROCEDURES AND PROPER USE OF THE EQUIPMENT ARE THE RESPONSIBILITY OF THE USER OF THIS SYSTEM.

Advanced Energy Industries, Inc. provides information on its products and associates hazards, but it assumes no responsibility for the after sale operation and safety practices.

ALL PERSONNEL WHO WORK WITH OR ARE EXPOSED TO THIS EQUIPMENT MUST TAKE PRECAUTIONS TO PROTECT THEMSELVES AGAINST POSSIBLE SERIOUS AND/OR FATAL BODILY INJURY.

DO NOT BE CARELESS AROUND THIS EQUIPMENT.

1. SAFETY

The high voltage nature of the output of these power supplies dictates the use of caution when near the output power connection.

Precautions:

- 1) Make certain that the chassis is properly grounded. THE GROUND CONNECTION PROVIDED SHOULD NOT BE DEFEATED!
- 2) The output connector is normally grounded. VOLTAGE LEVELS AT THE CONNECTOR MAY BE MORE THAN 1000 VOLTS DURING OPERATION.
- 3) THE PROTECTIVE COVERS SHOULD NOT BE REMOVED DURING OPERATION.

All internal adjustments may be made with the top cover removed but with the safety plexiglass shield in place. After adjustments are completed, the top cover should be replaced prior to turning on the power supply.

2. GENERAL DESCRIPTION

The RFX 600 is a two-stage power generator using a Fetpower™ modular power amplifier and a switchmode dc power supply for main power and control. The RFX is designed for 80% reflected power capability. It regulates output power using either forward power or dc bias of the load.

Its features allow it to be used alone or in combination with other supplies (through common exciter mode) in such configurations as RF with RF bias, RF with dc bias, and dc with RF bias.

3. SPECIFICATIONS

Power Output: 600 watts maximum into a 50 ohm load.

Harmonic Distortion: All harmonics are more than 50dB below the fundamental. Noise, hum and ripple are down by 30dB or greater below the fundamental.

Frequency: 13.56MHz \pm 0.005%

Output Impedance: 50 ohms

Output Power Regulation: \pm 3% of power setting for any load VSWR variation from 1:1 to 10:1 resistive (within auto protection limits).

Load Mismatch Tolerance: Continuous operation into any load mismatch without failure.

Pulsed Operation: Frequency range from zero to 10KHz maximum. Rise and fall times are less than 2.0 microseconds. Pulsing input is CMOS 15V compatible. Unit is capable of simultaneous and independent RF amplitude control and pulse operation.

Protection: Automatic foldback occurs when voltage, current or dissipation exceeds preset limits. Unit capable of up to 400 watts reflected power mismatch without foldback. Unit is completely protected from hardware damage due to open outputs.

RF Power Control: 0 to 600 watts with front panel control or remote 0 to 5 volt command.

Maximum Power Limit: Adjustable limit from zero to maximum output prevents excessive output during remote operation. Front panel setscrew adjustment. Setting may be observed on front panel digital display.

Automatic Forward Power Setting: 0 to 600 watts internally or externally controlled.

Efficiency: Variable switchmode dc input combined with Class D Fetpower™ output provides a minimum 60% overall efficiency from 100 watts to 600 watts output into 50 ohms resistive.

Regulation: Forward power or dc bias of the load.

Input Power: 115 VAC ± 10% or 230 VAC ± 10% single phase, 50/60 Hz.

Dual Supply Operation: Unit may operate either as master or slave or independent mode by logic level selection through a user connector on the rear panel (common exciter - "CEX TOGGLE").

Remote Operation: A user connector (25-pin subminiature D-type) is provided on the rear panel to allow remote operation or computer interface.

Diagnostic Connector: Rear panel subminiature (15-pin subminiature D-type) connector provides sufficient information to troubleshoot a problem to an internal module level without the need to open the cover.

Cooling: Forced air; maximum inlet ambient temperature is 40°C. Temperature monitors protect the unit from fan failure or airflow blockage.

Size:

6.97 in. (17.70 cm) Height
8.50 in. (21.59 cm) Width*
17.75 in (45.09 cm) Deep

***Add 2 inches (5.08 cm) to include removable rack ears**

Weight: 26.5 lbs. (12 Kg)

RF Output Connector: Type "N"

4. FRONT PANEL DISPLAY

Control

POWER - energizes unit. FWRD PWR (left) display) and REFL PWR (right display) light up.

Displays

LEFT DISPLAY - controls status of left display. Each time the push button is pressed, the display cycles through FWRD PWR, and DC BIAS.

RIGHT DISPLAY - controls status of right display. Each time the push button is pressed, the display cycles through REFL PWR, MAX PWR and PHASE ANGLE.

Regulation

FWD PWR LOAD PWR - provides forward power regulation control.

DC BIAS LOAD PWR - provides dc bias regulation control. Hole above this push button is a set screw adjustment to scale the dc Bias Control from 0-1000.

FWD PWR/DC BIAS - pressed together provides a load power regulation control.

5. REAR PANEL DISPLAY

2 ENC Connectors:

CEX OUT - 13.56MHz output signal from the exciter sub-assembly. Used in dual system operation as a master output to keep both units in phase.

CEX IN - 13.56MHz input signal to the power amplifier sub-assembly of the slaved unit in a dual system to keep both units in phase.

Circuit Breaker

The circuit breaker must be on to operate the unit.

6. CONNECTORS

Input Power Connections

The standard input power is 115V, 8.5A, single-phase, 50/60Hz.

Analog/digital I/O Connections

The user I/O interface uses a 25-pin, D-type connector. All analog signals are 0-5 V in and out. All digital signals are 0-15 V CMOS compatible.

Pin-description Table

<u>Pin</u>	<u>Name</u>	<u>Description</u>	<u>See page</u>
1	DC BIAS.A +	(+) Differential analog feedback input for dc bias regulation.	12
2	DC BIAS.A -	(-) Differential analog feed back input for dc bias regulation.	12
3	OFF/RESET.D	Digital remote input off/reset command. Referenced to pin 19.	12
4	ON.D*	Digital remote input on command. Referenced to pin 19.	12
5	PULSE ON.D	Digital remote input pulse output command. Referenced to pin 19.	13
6	CEX TOGGLE.D*	Digital input enable for common exciter. Referenced to pin 19.	13
7	PHASE ANGLE.A	Analog input representation of phase angle. Referenced to pin 18.	13
8	PHASE.D (+) (-)	Digital input representation indicating the sign of the phase angle, based on a user-provided signal. Referenced to pin 19.	13
9	PLASMA.D	Digital input indication of plasma presence from ATX tuner. Referenced to pin 19.	13
10	LOAD POWER IN.A	Analog input representation of load power, based on a user-provided signal. Referenced to pin 18.	13

Pin	Name	Description	See page
11	REMOTE PROGRAM.A LEVEL	Analog remote input power adjust. Referenced to pin 18.	14
12	TUNER ARC.D SENSE*	Digital input indication of chamber ARC, based on a user-provided signal. Referenced to pin 19.	14
13	INTLK.D	User access to digital interlock string. Referenced to pin 19.	14
14	REFLECTED.A POWER	Analog output representation of reflected power. Referenced to pin 18.	14
15	LOAD POWER.A	Analog output representation of load power, based on a user-provided signal. Referenced to pin 18.	14
16	DC BIAS.A	Analog output representation of chamber dc bias measured by user. Referenced to pin 18.	15
17	FORWARD POWER.A	Analog output representation of forward power. Referenced to pin 18.	15
18	SIGNAL COMMON	Common of all analog input/output signals.	15
19	POWER COMMON	Digital and control common.	15
20	TUNER OK.D	Digital input indication of satisfactory tuner operation from ATX tuner. Referenced to pin 19.	15
21	NOT USED		
22	NOT USED		
23	NOT USED		
24	NOT USED		
25	NOT USED		

* Negative true logic

Signal Descriptions: User I/O Pins

pin 1. dc BIAS.A +

The analog dc Bias (+) connection is the positive input to a differential operational amplifier for scaled feedback from the chamber. To use this input, a voltage divider of 200:1 should be established across the chamber electrodes. This ratio will provide 5 volts dc feedback at 1000 volts dc chamber bias. The maximum working voltage of the connection is 10 volts above ground. The more positive of the two feedback leads should be connected at this pin.

pin 2. DC BIAS.A (-)

The analog dc Bias (-) connection is the negative input to a differential operation amplifier for scaled feedback from the chamber. To use this input a voltage divider of 200:1 should be established across the chamber electrodes. This ratio will provide 5 volts dc feedback at 1000 volts dc chamber bias. The maximum working voltage of the connection is 10 volts below ground. The less positive of the two feedback leads should be connected at this pin.

pin 3. OFF/RESET.D

The remote digital OFF/RESET command duplicates the RF off of the front panel. This function overrides all other commands and forces the RFX drive to turn off, opens the main contactor and resets the interlock. A continuous digital low command (contact closure to power common, user Pin 19) is required to override the off command. The internal circuit has a 15 volt pull-up on it to provide the OFF command when contact closure to Pin 19 is interrupted.

The user connector plug shipped with a new RFX power supply has a jumper wire installed between OFF/RESET.D and power common. This will override the OFF command when this plug is installed.

pin 4. ON.D

The remote digital on command duplicates the RF on function of the front panel, when remote control has been selected at the front panel. A momentary contact closure of D. on to power common (User Pin 19) will cause RFX drive to turn on if OFF/RESET.D has been overridden. (See pin 3, OFF/RESET.D.)

A two-wire on command is possible with ON.D and OFF/RESET.D connected together. To accomplish this both must be connected to power common (User Pin 19) simultaneously to turn the RFX drive on.

pin 5. PULSE ON.A

This digital input enables the user to pulse the 13.56MHz output at rates up to 10KHz and duty cycles from 0-100%.

To pulse the output off, a digital low must be provided at this control pin. To pulse the output on, a +15 volts signal must be provided at this control pin.

pin 6. CEX TOGGLE.D

The digital common exciter toggle command enables the CEX in port, on the rear of the RFX supply. This command simultaneously disables the exciter within this power supply allowing for a common exciter signal to drive both supplies in synchronization through the CEX port. (Refer to the section pin 16, DC BIAS.A on page 15).

pin 7. PHASE ANGLE.A

Analog phase angle is an input representing the phase angle between the output voltage and current. This is a zero to 0-5 volt signal indicating 0-90 degrees.

pin 8. PHASE.D (+) (-)

Digital phase (+) (-) is an input representing the sign of the phase angle between the output voltage and current. A digital low indicates a voltage lag of a capacitive load.

pin 9. PLASMA.D

The digital plasma signal is an input from the ATX tuner indicating that the ATX tuner has sensed the presents of a plasma in the chamber.

pin 10. LOAD POWER IN.A

The analog load power signal is an input representing load power. This analog signal is scaled such that 0-5 volts equals 0 to full power rating.

pin 11. REMOTE PROGRAM LEVEL.A

Analog remote program level is a user input for remote control of the RFX output. To enable this input, "Remote Signal" must be selected at the front panel. An analog 0-5 volt signal will program 0 to full output of the RFX. This input signal must be referenced to signal common, user pin 18.

pin 12. TUNER ARC SENSE.D

The digital tuner arc signal is an input indicating a chamber arc. This is a digital low active signal.

pin 13. INTLK.D

The interlock function allows the user to gain access to the interlock string. With the string not satisfied the main contactor will not close, or if closed, will begin opening with 1 millisecond of the break. To satisfy the interlock command, contact closure to power common, user pin 19 must be made. When the interlock string has been satisfied, the "INTLK" status indicator on the front panel will be illuminated.

The user connector plug shipped with a new RFX power supply has a jumper wire installed between INTLK.D and power common. This will establish the interlock string when this plug is installed, enabling the unit to recognize an ON command.

pin 14. REFLECTED POWER.A

The analog reflected power signal is a scaled output signal representing reflected power as measured by the RFX. The scaling factor is: 0-5 volts represents zero to full reflected power of the RFX. The unit limits reflected power at 400 W, therefore 3.33 VDC is the maximum voltage present on pin 14.

pin 15. LOAD POWER.A

The analog true power signal is a scaled output signal representing true output power. The scaling factor is: 0-5 volts equals zero to full.

pin 16. DC BIAS.A

The analog dc bias signal is a scaled output signal representing chamber dc bias as measured by the ATX or the voltage divider/filter network (See the DC Bias Regulation section on page 18.) When properly calibrated, 0-5 volts equals 0-1000 volts dc bias.

pin 17. FORWARD POWER.A

The analog forward power signal is a scaled output signal representing forward power, as measured by the RFX. The scaling factor is: 0-5 volts represents 0 to 600 W of the RFX.

pin 18. SIGNAL COMMON

The signal common (ground) is a dedicated common for all user connector analog input and output signals.

pin 19. POWER COMMON

The power common (ground) is a dedicated common for all user connector digital and control input and output signals.

pin 20. TUNER OK.D

The digital tuner OK signal is an input from the ATX Tuner indicating satisfactory tuner operation. The signal is an active digital high.

DIAGNOSTIC CONNECTOR TABLE

(15 Pin, D-Type)

<u>Pin No.</u>	<u>Nomenclature</u>
1	D. C. Current
2	V - Limit
3	-
4	-
5	Primary Current
6	PWM Program
7	Level Setpoint
8	Unavailable
9	P.A. Ed
10	Exc Power
11	Signal Common
12	D. C. Enable
13	5V = 50V Bus
14	Fast Loop Program
15	+5V Reference

Dc Bias

"Dc bias" refers to the dc component of the RF power that is developed between the cathode and the anode of a typical RF plasma vacuum system. This dc component is blocked from the RF generator by the capacitors that are used in the impedance-matching networks.

The dc potential is a controllable parameter. It is also a valuable indicator that changes in response to changes in other process parameters. Some of the parameters that affect dc bias are molecular densities and ratios of process gases, cathode/anode surface area ratios, pressure regimes and stability, and RF power densities. While some of these parameters are controllable, others are fixed and so must be worked around.

The amount of dc bias that is developed within a process system depends upon the system design or the process being run. Although a systems manufacturer can use modeling or empirical data to predict the dc bias that should be expected with a specific system or process, a power supply manufacturer cannot.

In any case, you can determine dc bias by measuring it yourself with a high-voltage probe.

DANGER!

Lethal high-voltage and high-current potentials are present during the measurement of dc bias. Extreme caution is required to ensure the safety of yourself and of those working with you. Carelessness can cause severe burns, paralysis, or instant death.

Measure dc bias at the RF feedthrough. The farther the probe is from the feedthrough, the less accurate the measurement. This is because dc bias decreases with distance from the feedthrough due to electrical loss. A convenient point for taking this measurement is inside the impedance-matching network, at the output of the series capacitor.

Dc bias can be regulated in two ways, the choice of which depends upon the process or application. The mutually exclusive choices result in either maximum range or maximum resolution.

If you choose maximum range, run the RF generator at maximum power when you measure dc bias. In the more advanced, microprocessor-controlled RF generators, a normalization (calibration) function makes it possible to tailor the

process to the dc bias regulation. With one of these generators, maximum power will also equate with maximum dc bias. By normalizing for the maximum dc bias, the process will have the widest range of available dc biases.

If resolution of the dc bias control is more important, set your system up for a "typical" process before you measure dc bias. The new microprocessor- controlled generators will calibrate the dc bias over a smaller power cross section, thus providing a higher resolution over a smaller area of operation.

Since what is best for one application will not necessarily be best for another application, you may calibrate for either resolution or range, and then later repeat the process for the other possibility.

Dc BIAS REGULATION

The RFX 600 has the capability to regulate dc bias at the chamber. If you are using a tuner other than the ATX 600, you must provide a scaled and filtered dc bias feedback signal from the chamber to the RFX 600.

To scale the dc bias voltage a 200:1 voltage divider should be configured using a 2 megohm and a 10 kilohm high voltage resistor such as the Dale type "HVX3/4".

To filter the scaled dc bias feedback, a dual stage R/C filter should be configured with 1 kilohm resistors and 1000 picofarad capacitors. See Figure 1 for divider/filter configuration.

The feedback network is designed to scale 1000 volts dc chamber bias to a 5 volt dc feedback signal. The front panel left monitor will display chamber dc bias voltage directly. The maximum display digits is 1000 volts dc.

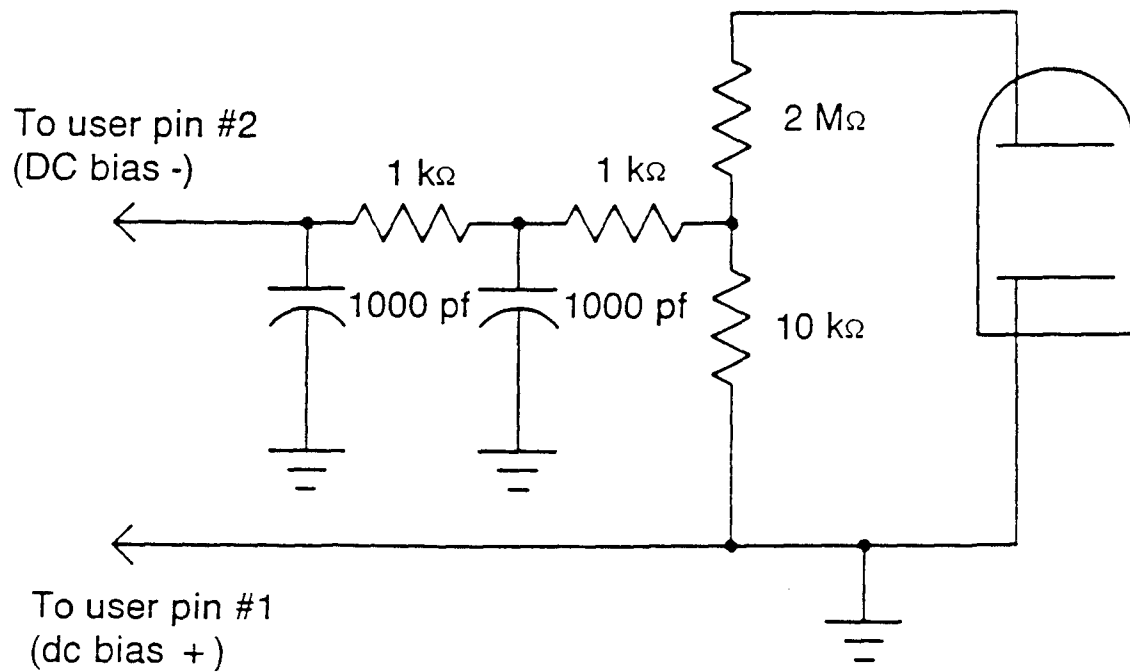

Figure 1. DIVIDER/FILTER CONFIGURATION

FIRST TIME OPERATION

Unpacking

DO NOT APPLY POWER TO THE UNIT BEFORE FOLLOWING THIS PROCEDURE:

Unpack and inspect your power supply carefully. Check for obvious physical damage.

Remove the top cover (6 phillips screws). Inspect the plexiglass shield for signs of physical damage and if none, replace cover and proceed to the connection section.

Start-up Procedure

1. Connect output connector to ATX.
2. Connect input power (115 VAC or 240 VAC).
3. Turn on breaker at rear of unit. Fan will turn on.
4. Press power push button on the front panel. Both displays will turn on, as well as the power LED, RF OFF LED, and any control button that is activated.
5. To set output level, select regulation mode (FWDPWR, DC BIAS, or LOAD PWR). Press SETPOINT push button and hold while adjusting power level. Observe left display for desired value. Release button.

CAUTION!

The next step will cause RF to be present at the output connector. Take appropriate steps to prevent electrical shock.

6. To enable output, press RF on. The main contactor will close and the output light will come on. The SETPOINT light will continue to flash until the output is delivering its preset level.

TROUBLESHOOTING

Controlling the unit from the front panel.

<u>Symptom</u>	<u>Action</u>
1. Front panel display won't light when the power switch is pressed. Fan does not come on.	a) Make certain the unit is plugged in. b) The breaker at the rear of the unit should be pulled up to the ON position.
2. The LED on the RF ON switch does not turn on when pressed.	a) Check to see if the remote control push button has been pressed. The LED on the push button should not be lit.
3. The LED is lit on the RF ON push button, but no output power.	a) Check the Remote Signal push button. The LED on the push button should not be lit. If lit push button one time. b) Check Maximum Power setting. If zero, rotate the Maximum Power potentiometer to the desired power level. c) Check CEX toggle: I/O connector pin 18 should not be pulled low unless using external CEX. d) Check pulse input should not be pulled low.